



TECHNICAL GUIDE

R-410A XP SERIES 15/20 TON 60 Hertz



XP180 Shown

Description

YORK® XP240 Sunline Magnum™ /XP180 Sunline™ Heat Pump units are convertible single package high efficiency rooftop units. All models have independent refrigeration circuits for efficient part load operation.

Although the units are primarily designed for curb mounting on a roof, they can also be mounted at ground level or set on steel beams above a finished roof.

All units are self-contained and assembled on rigid full perimeter base rails allowing for overhead rigging. Every unit is completely charged, wired, piped, and tested at the factory to provide a quick and easy field installation.

All models (including those with an economizer) are convertible between bottom and horizontal duct connections.

The heat pumps utilize a "demand defrost" control scheme. The unit will operate in heating mode until a combination of outdoor ambient and outdoor coil temperature indicate that a defrost cycle is necessary. The outdoor coil temperature must remain below the initiate point continuously for 4.5 minutes to eliminate any unnecessary defrost cycles.

Heat Pump units are available in the following configurations:

- Heat Pump without Electric Heat
- Heat Pump with Field Installed Electric Heat Accessory

Tested in accordance with:



Table of Contents

Description 1

Table of Contents 2

Component Location 3

Nomenclature 4

Prior Nomenclature 5

Features and Benefits 6

Guide Specifications 9

Physical Data 13

Capacity Performance 15

Airflow Performance 21

Sound Performance 26

Electrical Data 27

Weights and Dimensions 32

Component Location

(XP240)

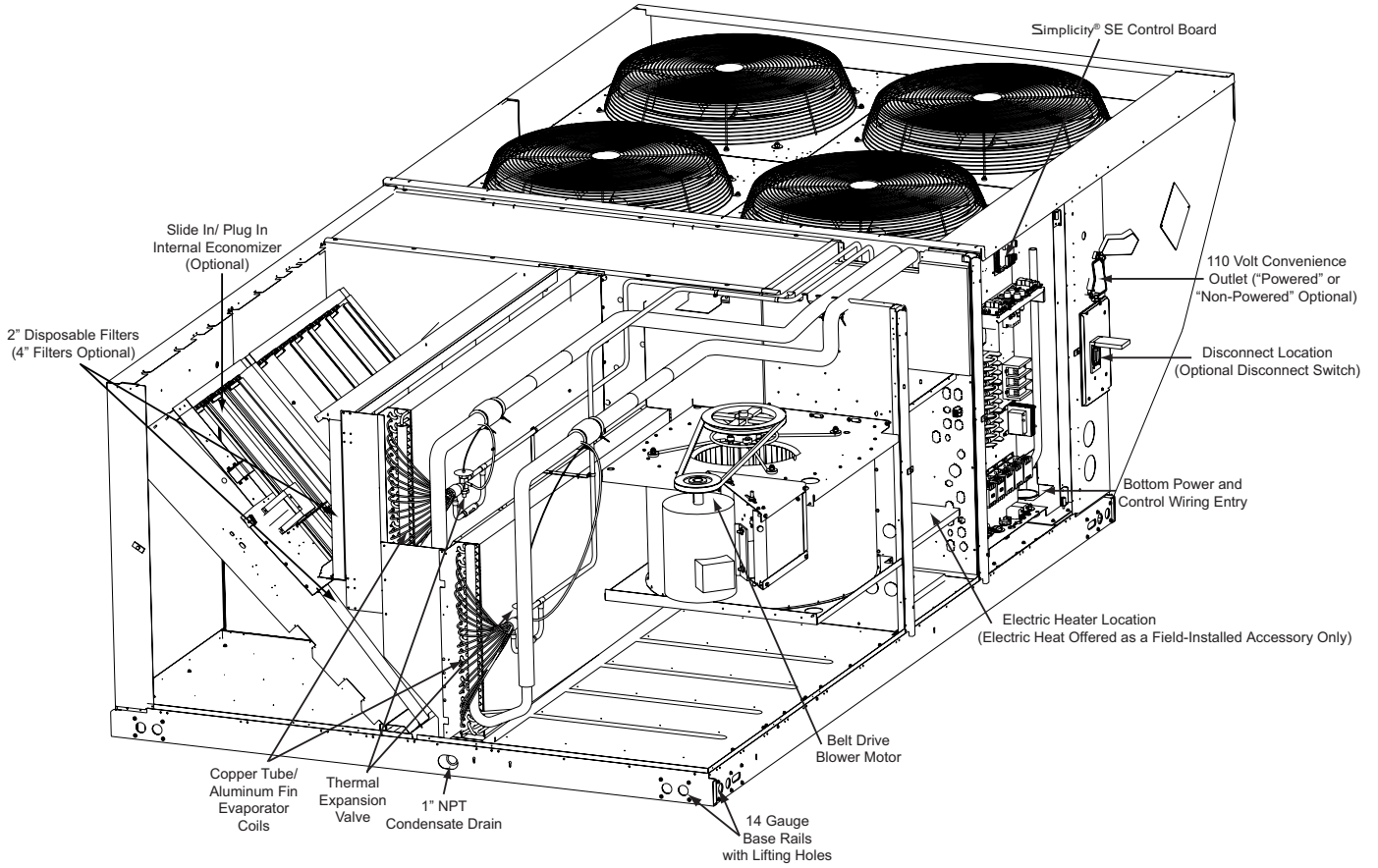

Nomenclature

15 & 20 Ton York® Model Number Nomenclature

X P 180 C 00 A 2 A 1 A A A 1 A 1

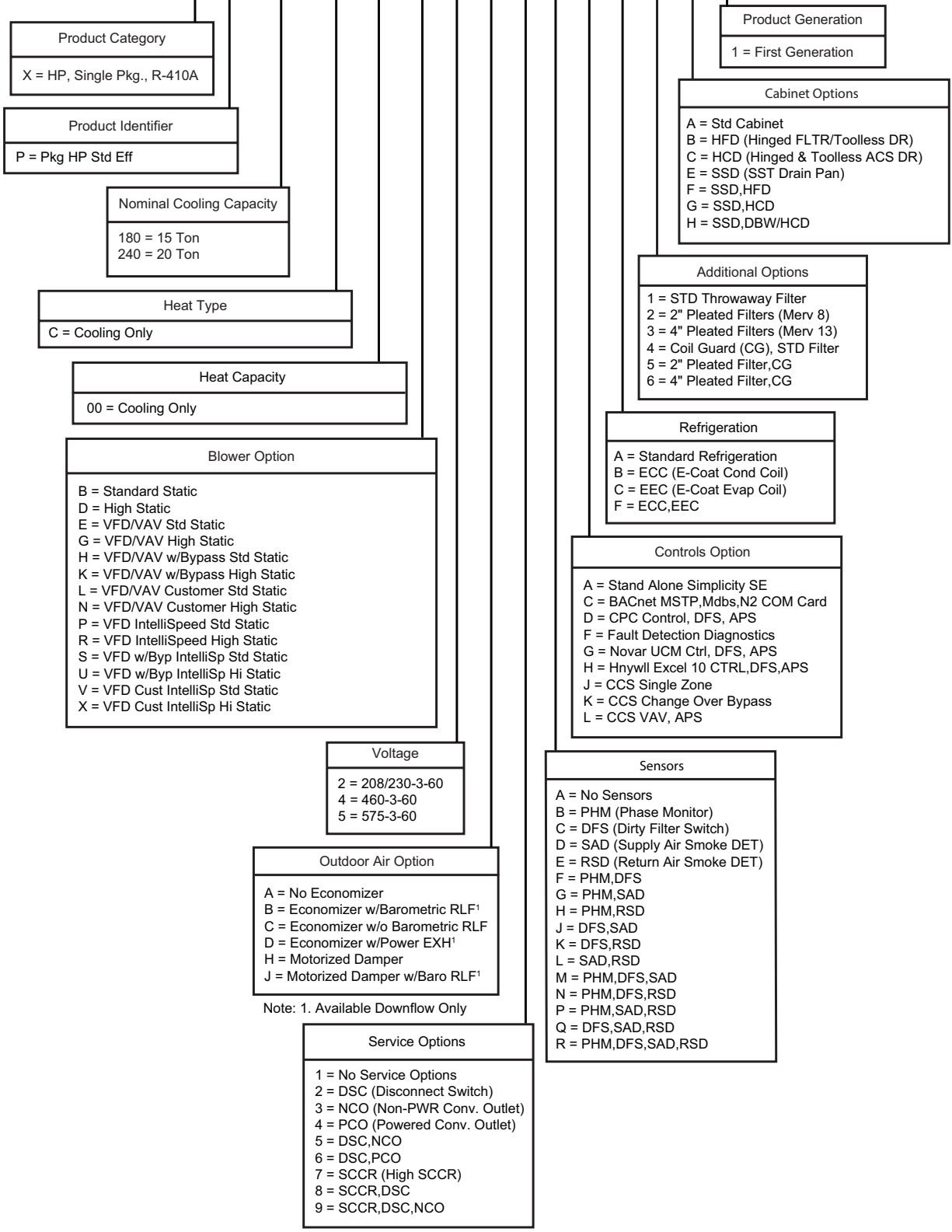

Prior Nomenclature

**15 Ton Sunline 2000 and 20 Ton Sunline Magnum™
Heat Pump Model Number Nomenclature For Units Produced Before 2-01-2016**

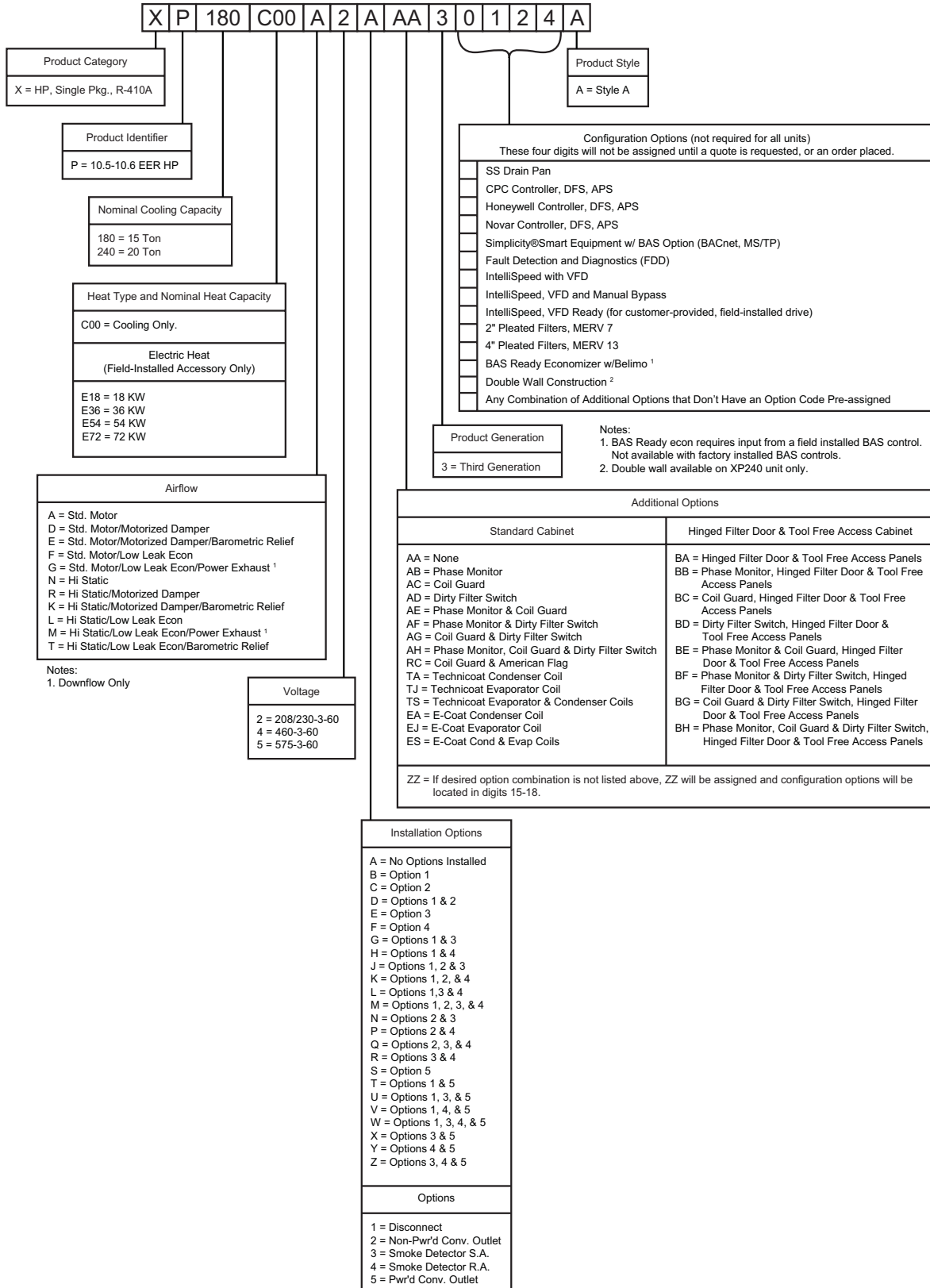

Features and Benefits

Standard Features

- **High Efficiency** - High efficiency units reach as high as 10.6 EER. These efficiencies exceed all legislated minimum levels and provide low operating costs.
- **Balanced Heating** -
 - **Electric Heat** - All electric heat models (field installed accessory only) are wired for a single power source and include a bank of nickel chromium elements mounted at the discharge of the supply air blower to provide a high velocity and uniform distribution of air across the heating elements. Every element is fully protected against excessive current and temperature by fuses and two thermal limit switches.
The power supply wiring can be routed into the control box through a threaded pipe connection in the base pan of the unit or through a knockout in the wiring panel on the front of the unit.
- **Unit Controllers** - York's Sunline™ series offer factory mounted Simplicity® SE UCB, with optional Communication board, a 4-stage board if 4 stages are required, an Economizer board, and an FDD (Fault Detection and Diagnostic) board. A MAP Device can be used to remotely access.
- **Convertible Airflow Design** - All models (including those with an economizer) are suitable for either bottom or horizontal duct connections. **Models with factory installed power exhaust are suitable for bottom duct connections only.** For bottom duct, you remove the sheet metal panels from the supply and return air openings through the base of the unit. For horizontal duct, you replace the supply and return air panels on the rear of the unit with a side duct flange accessory.
- **Factory Mounted Outdoor Air Dampers** - All models are available with these "factory mounted" outdoor air damper options:
 - Dry bulb economizer with or without power exhaust
 - Motorized outdoor air damper
 - Barometric Relief Damper

A fixed outdoor air intake assembly will be shipped in the return air compartment of all units ordered without an economizer or motorized outdoor air damper option. The assembly includes a rain hood with a baffle that can be set for 10, 15 or 25% outdoor air. With bottom duct connections, the fixed outdoor air intake assembly should be mounted over the opening in the return air panel. With horizontal ductwork, it should be mounted on the return air duct.
- **System Protection** - Suction line freezestats are supplied on all units to protect against loss of charge and coil frosting when the economizer operates at low outdoor air temperatures while the compressors are running. Every unit has solid-core liquid line filter-driers and high and low-pressure switches. Internal compressor protection is standard on all compressors. Phase Monitors are optional on all units. This accessory monitors the incoming power to the unit and protects the unit from phase loss and reversed phase rotation.

- **Advanced Controls** - XP Models have Simplicity® SE control boards that standardized a number of features previously available only as options or by utilizing additional controls.

CAUTION

The Simplicity® SE control board used in this product will effectively operate the cooling system down to 0°F when this product is applied in a comfort cooling application for people. An economizer is typically included in this type of application. When applying this product for process cooling applications (computer rooms, switchgear, etc.), please reference applications bulletin AE-011-07 or call the applications department for Unitary Products @ 1-877-UPG-SERV for guidance. Additional accessories may be needed for stable operation at temperatures below 30°F.

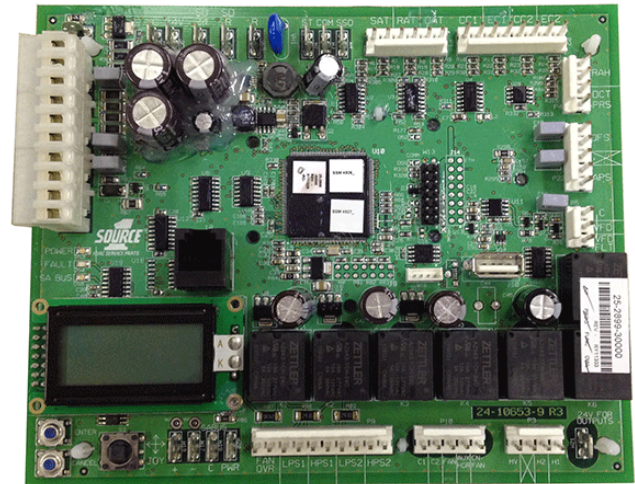

- **Units will come with the new state of the art Simplicity SE (Smart Equipment) control system.** The new unit control incorporates the best of the already proven Simplicity™ unitary controls and creates a more robust, intelligent control. The goal of this control is to utilize cutting edge technology making the equipment easier to install, operate, and service. All units are Factory commissioned, configured, and run tested.
- **Versatile** - The Simplicity SE control can be configured to use with a standard thermostat (easy to connect screw terminals), A zone sensor, or can be setup to communicate with multiple BAS communication protocols to integrate with building automation systems.
- **Reduce field installed complexity** - Each unit will come equipped with factory installed supply air, return air, and outdoor air temperature sensors providing key temperature readings thus reduce field installed complexity.

- **On-board USB Port** - The new control comes with a long list of features including data logging, current and previous system faults and software update capabilities using the on board USB port and common flash drive. Energy use monitoring capabilities allow custom tailoring to allow a system to work more efficiently at all times and occupancy levels. Self test and start-up reports also available from the board VIA the USB port.
- **Embedded LCD Display** - The board has a easy to read, built-in LCD display and easy to use navigation joystick and buttons allowing the user to quickly navigate the menus displaying unit status, options, current function, supply, return and outdoor temperatures, fault codes and other information.
- **Safety Monitoring** - The control monitors the outdoor, supply, and return air temperatures and the high and low pressure switch status on the independent refrigerant circuits. On units with heating the gas valve and high temperature limit switches are monitored on gas and electric heating units. The control also monitors the voltage supplied to the unit and will protect the unit if low voltage due to a brown out, or other electrical issue occurs.
- **Low Ambient** - An integrated low-ambient control allows units to operate in the cooling mode down to 0°F outdoor ambient without additional components or intervention. Optionally, the control board can be programmed to lockout the compressors when the outdoor air temperature is low or when free cooling is available.
- **Anti-Short Cycle Protection** - To aid compressor life, an anti- short cycle delay is incorporated into the standard control. Compressor reliability is further ensured by programmable minimum run times. For testing, the anti-short cycle delay can be temporarily overridden with the push of a button.
- **Fan Delays** - Fan on and fan off delays are fully programmable. Furthermore, the heating and cooling fan delay times are independent of one another. All units are programmed with default values based upon their configuration of cooling and/or heating capacity.
- **Nuisance Trip Protection and Three Strikes** - To prevent nuisance calls, the control board uses a three times, you're out philosophy. The high, low-pressure switch, anti-freeze protection, low voltage or heating high limit must trip three times within two hours before the unit control board will lock out the associated compressor. An alarm message will be displayed on the LCD screen.
 - **Lead-Lag** - An integrated Lead-Lag option allows equal run time hours on all compressors, thereby extending the life of all compressors. This option is selectable on the unit control board.
- **Reliable** - From the beginning - All units undergo computer automated testing before they leave the factory. Units are tested for refrigerant charge and pressure, unit amperage, and 100% functionality. For the long term - All units are painted with a long lasting, powder paint that stands up over the life of the unit. The paint used has been proven by a 1000 hour salt spray test.
- **Full Perimeter Base Rails** - The permanently attached base rails provide a solid foundation for the entire unit and protect the unit during shipment. The rails offer rigging holes so that an overhead crane can be used to place the units on a roof.
- **Easy Installation** - Gas and electric utility knockouts are supplied in the unit underside as well as the side of the unit. Utility connections can be made quickly and with a minimum amount of field labor. All units are shipped with 2" throw-away filters installed.
- **Wide Range of Indoor Airflows** - All supply air blowers are equipped with a belt drive that can be adjusted to meet the exact requirements of the job. A high static drive option is available for applications with a higher CFM and/or static pressure requirement.
- **Warranty** - All models include a 1-year limited warranty on the complete unit. Compressors and electric heater elements each carry a 5-year warranty. Aluminized steel tubular heat exchangers carry a 10 year warranty. Stainless steel heat exchangers a 15 year warranty.

Factory Installed Options

YORK® offers several equipment options factory installed, for the XP Series.

- **Dry Bulb Economizers** - All units offer a variety of optional factory installed down flow economizers that are shipped, installed and wired with low leak dampers designed to meet ASHRAE 90.1-2010, AMCA 511 Class 1A damper, and the International Energy Conservation Code (IECC) certification requirements by achieving leakage rates of 3 cfm/sq. ft. at 1" of static pressure. Each economizer goes through a rigorous 60,000 cycle test. Dry bulb, single enthalpy, and dual enthalpy (with field installed kit) can be selected. All economizer options are fully integrated into the Simplicity® SE controls. The economizer has spring return, fully modulating damper actuators and is capable of introducing up to 100% outdoor air. As the outdoor air intake dampers open, the return air dampers close. The changeover from mechanical refrigeration to economizer operation is regulated by the outdoor air dry bulb temperature or the outdoor air enthalpy input. The dual enthalpy kit provides a second input used to monitor the return air (field installed). The installer needs only to assemble the outdoor air hood, attach the enthalpy control the hood and mount the hood to the unit (Hood and control are provided).
- **Power Exhaust** - Our economizer options are available with power exhaust. Whenever the outdoor air intake dampers are opened for free cooling, the exhaust fan will be energized to prevent the conditioned space from being over-pressurized during economizer operation. The exhaust fan, motor and controls are installed and wired at the factory. The rain hood must be assembled and installed in the field. The power exhaust option can only be used on bottom duct configurations.
- **Motorized Outdoor Air Intake Damper** - Includes a slide-in / plug-in damper assembly with a 2- position,

spring return motor actuator which opens to a pre-set position whenever the supply air blower is operating and will drive fully closed when the blower unit shuts down.

The rain hood is painted to match the basic unit and must be field assembled before installing.

- **Barometric Relief Damper** - This damper option can be used to relieve internal building air pressure on units with an economizer without power exhaust. This accessory includes a rain hood, a bird screen and a fully assembled damper. With bottom duct connections, the damper should be mounted over the opening in the return air panel. With horizontal ductwork, the accessory should be mounted on the return air duct.
- **E-Coat Condenser Coils** - The condenser coils are coated with an epoxy polymer coating to protect against corrosion.
- **E-Coat Evaporator Coils** - The evaporator coils are coated with an epoxy polymer coating to protect against corrosion.
- **Filter Options** - Standard units are shipped with 2" throw-away filters installed. 2" pleated and 4" pleated filters are offered as a factory installed option.
- **IntelliSpeed™ Supply Fan Control Option (ASHRAE 90.1 compliant, section 6.4.3.10)** - Units configured with the IntelliSpeed™ Supply Fan Option will contain a VFD for multi-speed supply fan operation. This option allows the supply fan RPM to vary based on the number of compressors or heating stages energized. The economizer's minimum position will also be configurable to vary based on the supply fan VFD frequency output.
- **Convenience Outlet** - This 110 volt outlet can be "powered" by the unit with a stepdown transformer or you may order the unit with a "non-powered" convenience outlet that can be wired in the field.
- **Disconnect Switch** - For heat pump only units, a disconnect switch sized to the largest electric heat available for the particular unit is provided. Factory installed option only.
- **Double Wall Construction (XP240 only)** - Optional double wall construction is available to provide smooth inner surfaces for easy and effective cleaning to reduce risk of dirt and bacterial accumulation. Fiberglass insulation is sandwiched between heavy gauge steel sheets to form a durable, rigid casing to withstand higher working pressures and impact forces. The heavy-duty construction provides excellent acoustic and thermal insulation and eliminates erosion of insulation material and contamination of the air stream.
- **Smoke Detectors** - (supply air & return air) The smoke detectors stop operation if smoke is detected within the air compartment.

▲ WARNING

Factory installed smoke detectors in the return air, may be subjected to freezing temperatures during "off" times due to outside air infiltration. These smoke detectors have an operational limit of -4°F to 158°F. Smoke detectors installed in areas that could be outside those limitations will have to be moved to prevent having false alarms.

- **Coil Guard** - Customers can purchase a coil guard kit to protect the condenser coil from damage. This is not a hail guard kit.
- **Stainless Steel Drain Pan** - An optional rustproof stainless steel drain pan is available to provide years of trouble-free operation in corrosive environments.
- **Phase Monitors** - Designed to prevent unit damage. The phase monitor will shut the unit down in an out-of-phase condition.
- **High Static Drive** - Includes a belt, blower pulley, and a motor change to enhance blower performance.
- **Dirty Filter Switch** - This kit includes a differential pressure switch that energizes the fault light on the unit thermostat, indicating that there is an abnormally high pressure drop across the filters. Factory installed option or field installed accessory.
- **Hinged Filter Door/"Tool Free" Blower And Access Panels (Not Hinged)** - This option allows for easy access and maintenance.

NOTE: Knobs are shipped separately within the unit to prevent shipping damage. These must be field installed for tool free operation.

- **Hinged/"Tool Free" Blower, Blower Motor, Filter And Electric Access Panels** - This option allows for complete hinged and tool free access to the unit's blower, blower motor, filters and electrical panel sections.

Field Installed Accessories

YORK® offers several equipment accessories for field installation, for the XP Series.

- **Dry Bulb Economizers** - All units offer a variety of optional factory installed down flow economizers that are shipped, installed and wired with low leak dampers designed to meet ASHRAE 90.1-2010, AMCA 511 Class 1A damper, and the International Energy Conservation Code (IECC) certification requirements by achieving leakage rates of 3 cfm/sq. ft. at 1" of static pressure. Each economizer goes through a rigorous 60,000 cycle test. Dry bulb, single enthalpy, and dual enthalpy (with field installed kit) can be selected. All economizer options are fully integrated into the Simplicity SE controls. The economizer has spring return, fully modulating damper actuators and is capable of introducing up to 100% outdoor air. As the outdoor air intake dampers open, the return air dampers close. The changeover from mechanical refrigeration to economizer operation is regulated by the outdoor air dry bulb temperature or the outdoor air enthalpy input. The dual enthalpy kit provides

a second input used to monitor the return air (field installed). The installer needs only to assemble the outdoor air hood, attach the enthalpy control the hood and mount the hood to the unit (Hood and control are provided).

- **Motorized Outdoor Air Intake Damper** - Includes a slide-in / plug-in damper assembly with a 2-position, spring return motor actuator which opens to some pre-set position whenever the supply air blower is operating and will drive fully closed when the blower unit shuts down. The rain hood is painted to match the basic unit and must be field assembled before installing.
- **Roof Curbs** - Fourteen-inch high roof curbs provide a water-tight seal between the unit and the finished roof. These full perimeter curbs meet the requirements of the National Roofing Contractors Association (NRCA) and are shipped knocked-down for field assembly. They're designed to fit inside the base rails of the unit and include both a wood nailing strip and duct hanger supports.
- **Side Duct Flanges** - One-inch flanges replace the supply and return air panels on the rear of the unit to accommodate horizontal duct connections. These flanges can also be used individually for bottom supply / horizontal return or horizontal supply/bottom return. They cannot be used on units with power exhaust.
- **Barometric Relief Damper** - This damper accessory can be used to relieve internal building air pressure on units with an economizer without power exhaust. This accessory includes a rain hood, a bird screen and a fully assembled damper. With bottom duct connections, the damper should be mounted over the opening in the return air panel. With horizontal ductwork, the accessory should be mounted on the return air duct.
- **High Static Drive** - Includes a belt and blower pulley to enhance blower performance. (XP180 only)
- **Enthalpy Accessory Control Kit** - This kit contains the required components to convert a single enthalpy economizer to dual enthalpy.
- **Burglar Bars** - Mount in the supply and return openings to prevent entry into the duct work.
- **Wood Skid** - Allows unit to be handled with 90" forks.
- **CO₂ Sensor** - Senses CO₂ levels and automatically overrides the economizer when levels rise above the present limits.
- **Coil Guard** - Customers can purchase a coil guard kit to protect the condenser coil from damage. This is not a hail guard kit.
- **Phase Monitors** - Designed to prevent unit damage. The phase monitor will shut the unit down in an out-of phase condition.
- **Electric Heaters** - wired for single point power supply. These nickel chromium heater elements are provided with limit and automatic reset capability to prevent operation at excessive temperatures.

Control Options

Simplicity® SE with Communication Option Control - The York® Simplicity® SE with Communication Option Control is factory installed. It includes all the features of

the Simplicity® SE control with an additional gateway to BACnet MS/TP (programmable to Modbus or N2 protocols).

FDD (Fault Detection and Diagnostics) - Refrigerant side

A factory installed control system option on the commercial equipment that constantly monitors refrigerant circuit pressures, refrigerant circuit temperatures, as well as the environmental temperatures and humidity via multiple sensor inputs.

- Provides a building owner, technician or contractor with the operational characteristics of the RTUs entire refrigerant circuit to ensure the unit is functioning at its specified performance level.
- Provides alarms if the unit is not functioning optimally.
- Remotely accessible via the Mobile Access Portal (MAP) gateway as well as scrolled on the UCB LCD screen.

Novar® BAS Control - The Novar® building automation system controller is factory installed. Includes supply air sensor, return air sensor, dirty filter indicator switch, and air proving switch.

CPC BAS Control - The Computer Process Controls Model 810-3060 ARTC Advanced Rooftop building automation system controller is factory installed. Includes supply air sensor, return air sensor, with optional dirty filter indicator switch and air proving switch.

Honeywell BAS Control - The Honeywell W7750C building automation system controller is factory installed. Includes air supply sensor, return air sensor, with optional dirty filter indicator switch, and air proving switch.

Guide Specifications

General

Units shall be manufactured by Johnson Controls Unitary Products in an ISO 9001 certified facility.

York's XP units are convertible single package Heat Pump units. XP models have dual independent refrigerant circuits for efficient part load operation and maximum comfort control. Although the units are primarily designed for curb mounting on a roof, they can also be slab-mounted at ground level or set on steel beams above a finished roof. Heat Pumps are available with a wide variety of factory-mounted options and field-installed accessories to make them suitable for almost every application. All units are self-contained and assembled on full perimeter base rails with holes in the four corners for overhead rigging. Every unit is completely piped, wired, charged and tested at the factory to simplify the field installation and to provide years of dependable operation. All models (including those with an economizer) are suitable for either bottom or horizontal duct connections. Models with factory installed power exhaust are suitable for bottom duct connections only. For bottom duct, remove the sheet metal panels from the supply and return air openings through the base of the unit. For horizontal duct, replace the supply and return air panels on the rear of the unit with a side duct flange accessory. All supply air blowers are equipped with a belt drive that can be adjusted to meet the exact requirements of the job. A high static drive

option is available for applications with a higher CFM and/or static pressure requirement.

XP240 models have 4 condenser fan motors and XP180 models have 2 condenser fan motors. All compressors include crankcase heat and internal pressure relief. Every refrigerant circuit includes an expansion valve, a liquid line filter-drier, a discharge line high pressure switch and a suction line with a freestat and low pressure/loss of charge switch. The unit control circuit includes a 75 VA transformer, a 24-volt circuit breaker and a relay board with two compressor lockout circuits, a terminal strip for thermostat wiring, plus an additional set of pin connectors to simplify the interface of additional field controls. All units have long lasting powder paint cabinets with 1000 hour salt spray test approval under ASTM-B117 procedures. All models are CSA approved. All models include a 1-year limited warranty on the complete unit. Compressors and electric heater elements carry an additional 4-year warranty.

Description

XP units shall be factory-assembled, single packaged, XP Heat Pump/Or Heat Pump with Field installed Electric Heat Accessory, designed for outdoor mounted installation. The 15 ton unit shall have a minimum EER rating of 10.6. The 20 ton unit shall have a minimum EER rating of 9.5.

They shall have built-in field convertible duct connections for down discharge supply/return or horizontal discharge supply/return, and be available with factory installed options or field installed accessories. The units shall be factory wired, piped, charged with R-410A refrigerant and factory tested prior to shipment. All unit wiring shall be both numbered and color coded. All units shall be manufactured in a facility certified to ISO 9001 standards and the cooling performance shall be rated in accordance with DOE and AHRI test procedures. Units shall be CSA listed, classified to ANSI Z21.47 standards, UL 1995/CAN/CSA No. 236-M90 conditions.

Unit Cabinet

Unit cabinet shall be constructed of galvanized steel, with exterior surfaces coated with a non-chalking, powdered paint finish, certified at 1000 hours salt spray test per ASTM-B117 standards. Indoor blower section shall be insulated with a minimum 1/2" thick insulation, coated on the airside. Aluminum foil faced insulation shall be used in the furnace compartment and be fastened with ridged fasteners to prevent insulation from entering the air stream. Cabinet panels shall be "large" size, easily removable for servicing and maintenance. Full perimeter base rails shall be provided to assure reliable transit of equipment, overhead rigging and proper sealing on roof curb applications. Disposable 2" filters shall be furnished and be accessible through a removable access door, sealed airtight. Units filter track shall be designed to accommodate either 2" or 4" filters. Fan performance measuring ports shall be provided on the outside of the cabinet to allow accurate air measurements of evaporator fan performance without removing panels or creating air by-pass of the coils. Condensate pan shall be internally sloped and conform to ASHRAE 62-89 self-

draining standards. Condensate connection shall be a minimum of 1" I.D. female and be a ridged mount connection. Unit shall incorporate a fixed outdoor air damper with an outdoor air intake opening covered with a bird screen and a rain hood painted to match the exterior of the unit.

Indoor (Evaporator) Fan Assembly

Fan shall be a belt drive assembly and include an adjustable-pitch motor pulley. Job site selected (B.H.P.) brake horsepower shall not exceed the motors nameplate horsepower rating, plus the service factor. Units shall be designed not to operate above service factor. Fan wheel shall be double-inlet type with forward-curved blades, dynamically balanced to operate smoothly throughout the entire range of operation. Airflow design shall be constant air volume.

Outdoor (Condenser) Fan Assembly

The outdoor fans shall be of the direct-driven propeller type, discharge air vertically, have aluminum blades riveted to corrosion resistant steel spider brackets and shall be dynamically balanced for smooth operation. The 2 outdoor fan motors (15 ton) and 4 outdoor fan motors (20 ton) shall be totally enclosed with permanently lubricated bearings, internally protected against overload conditions and staged independently.

Refrigerant Components

Compressors:

- a. Shall be Scroll compressors internally protected with internal high-pressure relief and over temperature protection.
- b. Shall have internal spring isolation and sound muffling to minimize vibration and noise, and be externally isolated on a dedicated, independent mounting.

Coils:

- a. Evaporator and condenser coils shall have aluminum plate fins mechanically bonded to seamless internally enhanced copper tubes with all joints brazed. Special Phenolic coating shall be available as a factory option.
- b. Evaporator and Condenser coils shall be of the direct expansion, draw-thru, design.

Refrigerant Circuit and Refrigerant Safety Components shall include:

- a. Balance-port thermostatic expansion valve with independent circuit feed system.
- b. Filter drier/strainer to eliminate any moisture or foreign matter.
- c. Accessible service gage connections on both suction and discharge lines to charge, evacuate, and measure refrigerant pressure during any necessary servicing or troubleshooting, without losing charge.
- d. The refrigeration system shall provide at least 15° F of sub-cooling at design conditions.

Unit Controls

- a. Unit shall be complete with self-contained low-voltage control circuit protected by a resettable circuit breaker on the 24-volt transformer side.
- b. Unit shall incorporate a lockout circuit which provides reset capability at the space thermostat or base unit, should any of the following standard safety devices trip and shut off compressor.
 1. High-pressure switch.
 2. Freeze condition sensor, evaporator coil. If any of these safety devices trip, the LCD screen will display the alarm message.
- c. Loss-of-charge/Low-pressure switch.
 1. High-pressure switch.
 2. Freeze condition sensor, evaporator coil. If any of these safety devices trip, the LCD screen will display the alarm message.
- d. Unit shall incorporate "AUTO RESET" compressor over temperature, over current protection.
- e. Unit shall operate with conventional thermostat designs and have a low voltage terminal strip for easy hook-up.
- f. Unit control board shall have on-board diagnostics and fault message display.
- g. Standard controls shall include anti-short cycle and low voltage protection, and permit cooling operation down to 0 °F.
- h. Control board shall monitor each refrigerant safety switch independently.

Electric Heating (Field Installed Accessory Only)

Nickel chromium electric heating elements shall be provided as required by the application with 1 or 2 stage control, as required, from 18 KW to 72 KW capacities. The heating section shall have a primary limit control(s) and automatic reset to prevent the heating element system from operating at an excessive temperature. Units with Electric Heating shall be wired for a single point power supply with branch circuit fusing (where required).

Unit Operating Characteristics

Unit shall be capable of starting and running at 125° F outdoor temperature, exceeding maximum load criteria of AHRI Standard 340/360. The compressor, with standard controls, shall be capable of operation down to 25° F outdoor temperature.

Electrical Requirements

All unit power wiring shall enter unit cabinet at a single factory provided location and be capable of side or bottom entry, to minimize roof penetrations and avoid unit field modifications. Separate side and bottom openings shall be provided for the control wiring.

Standard Limited Warranties

- Compressor 5 Years
- Electric Heat Element 5 Years
- Other Parts 1 Year

Optional Outdoor Air (Shall be made available by either/or):

- **Dry Bulb Economizer** - Outdoor and return air dampers that are interlocked and positioned by a fully-modulating, spring-return damper actuator. The maximum leakage rate for the outdoor air intake dampers shall be designed to meet ASHRAE 90.1-2010, AMCA 511 Class 1A damper, and the International Energy Conservation Code (IECC) certification requirements by achieving leakage rates of 3 cfm/sq. ft. at 1" of static pressure. During economizer operation, a mixed-air temperature control shall modulate the outdoor and return air damper assembly to prevent the supply air temperature from dropping below 55°F. Changeover from compressor to economizer operation shall be provided by an integral electronic enthalpy control that feeds input into the basic module. The outdoor intake opening shall be covered with a rain hood that matches the exterior of the unit. Water eliminator/filters shall be provided. Simultaneous economizer/compressor operation is also possible. Dampers shall fully close on power loss.
- **Motorized Outdoor Air Dampers** - Outdoor and return air dampers that are interlocked and positioned by a 2-position, spring-return damper actuator. A unit-mounted potentiometer shall be provided to adjust the outdoor and return air damper assembly to take in the design CFM of outdoor air to meet the ventilation requirements of the conditioned space during normal operation. Whenever the indoor fan motor is energized, the dampers open up to one of two pre-selected positions - regardless of the outdoor air enthalpy. Dampers return to the fully closed position when the indoor fan motor is de-energized. Dampers shall fully close on power loss.

OTHER FACTORY INSTALLED OPTIONS

- **Power Exhaust Option** - To work in conjunction with economizers.
- **Stainless Steel Drain Pan**
- **E-Coat Epoxy Polymer Coated Condenser And Evaporator Coil**
- **Electronic Single Enthalpy Economizer**
- **Dirty Filter Switch**
- **Double Wall (XP240 only)**
- **Phase Monitor**
- **Coil Guard**
- **Powered GFI Convenience Outlet**
- **Non-powered GFI Convenience Outlet**
- **BAS Controls** - Simplicity® SE with BAS Communication (BACnet MS/TP, Modbus, and Johnson Controls N2) Option, CPC, HONEYWELL, NOVAR, YORK COMMERCIAL COMFORT SYSTEM (YCCS)
- **BAS Ready Economizer** (2-10 V.D.C. Actuator With Simplicity® SE Controller)
- **Hinged Filter Door Access And Tool Free Access Panels**
- **Hinged Tool Free Blower, Blower Motor, Filter And Electrical Access Panels**

- **High Static Drive**
- **2" Pleated Filters, MERV 8**
- **4" Pleated Filters, MERV 13**
- **Disconnect Switch**
- **Supply Air Smoke Detector**
- **Return Air Smoke Detector**
- **Electric Heat Kits (Field Installed Accessory)**

Other Pre-engineered Accessories Available

- **Roof Curb** - 14" high, full perimeter curb with wood nailer (shipped knocked-down).
- **100% Barometric Relief Damper** - Contains a rain hood, air inlet screen, exhaust damper and mounting hardware. Used to relieve internal air pressure through the unit.

- **Burglar Bars** - Designed to work with above roof curbs, depending on unit model. Fits duct openings of curb supply and return air openings.
- **Side Duct Flange** - Supply and return air duct flanges for side duct applications. Do not use on units with power exhaust.
- **High Static Drive** - May include a belt, blower pulley, motor pulley or a motor change to enhance blower performance.
- **Wood Skid** - Allows unit to be handled with 90" forks.
- **Economizer/motorized Damper** - Contains all hood panels and the hardware for assembling.
- **Anti-Recycle Timer** - Assures 5-minute off time between compressor cycles.
- **Low Ambient Kit** - Provides unit cooling operation down to 0 °F.
- **Coil Guard Kit** - Guard for cooling coil.

Physical Data

XP180/240 Physical Data

Component	Models			
	XP180		XP240	
Nominal Tonnage	15		20	
AHRI COOLING PERFORMANCE				
Gross Capacity @ AHRI A point (Btu/hr)	181,600		261,400	
AHRI net capacity (Btu/hr)	176,000		250,000	
EER	10.6		9.5	
IEER with Constant Volume	11.8		9.9	
IEER with Intellispeed	13.2		11.2	
IEER with VAV	11.8		9.9	
Nominal CFM	5500		8000	
System power (KW)	16.5		23.8	
Refrigerant type	R-410A		R-410A	
Refrigerant charge (lb-oz)				
System 1	23-0		28-0	
System 2	23-4		29-0	
AHRI HEATING PERFORMANCE				
47 F Net Capacity (Btu/hr)	162,000		260,000	
System power (KW) / COP	14.62 / 3.24		23.80 / 3.20	
17 F Net Capacity (Btu/hr)	99,000		136,000	
System power (KW) / COP	13.62 / 2.05		20.96 / 2.00	
DIMENSIONS (inches)				
Length	136-1/4		180-19/32	
Width	92		92	
Height	52-5/8		52-5/8	
OPERATING WT. (lbs.)				
2140				
COMPRESSORS				
Type	Scroll		Scroll	
Quantity	2		2	
Unit Capacity Steps (%)	50 / 100		50 / 100	
CONDENSER COIL DATA				
Face area (Sq. Ft.)	43.3		63.8	
Rows	3		2	
Fins per inch	15		20	
Tube diameter (in.)	3/8		3/8	
Circuitry Type	Split-face		Split-face	
EVAPORATOR COIL DATA				
Face area (Sq. Ft.)	20		25	
Rows	4		4	
Fins per inch	13.5		15	
Tube diameter	3/8		3/8	
Circuitry Type	Inter-twined		Split-face	
Refrigerant control	TXV		TXV	
CONDENSER FAN DATA				
Quantity	2		4	
Fan diameter (Inch)	30		30	
Type	Prop		Prop	
Drive type	Direct		Direct	
No. speeds	1		1	
Number of motors	2		4	
Motor HP each	1.25		0.5	
RPM	1140		1075	
BELT DRIVE EVAP FAN DATA				
Quantity	1		1	
Fan Size (Inch)	18 X 15		18 X 15	
Type	Centrifugal		Centrifugal	
Motor Sheave	1VP60	1VP60	1VP60	1VP60
Blower Sheave	BK120	BK100	BK110	BK090
Belt	BX81	BX78	BX78	BX75
Motor HP each	5	7.5	7.5	10
RPM	1750	1750	1750	1760
Frame size	184T	213T	213T	215T
FILTERS				
Quantity - Size	4 - (16 x 25 x 2),		12 - (12 x 24 x 2) ^{1,2}	
	4 - (16 x 20 x 2) ^{1,2}			
	4 - (16 x 25 x 4),		2 - (20 x 24 x 4),	
	4 - (16 x 20 x 4) ³		12 - (12 x 24 x 4) ³	

1. 2 In. Throwaway, Standard, MERV (Minimum Efficiency Reporting Value) 3.

2. 2 In. Pleated, Optional, MERV 8.

3. 4 In. Pleated, Optional, MERV 13.

XP180/240 Unit Limitations

Size (Tons)	Unit Voltage	Unit Limitations		
		Applied Voltage		Outdoor DB Temp
		Min	Max	Max (°F)
180 (15)	208/230-3-60	187	252	125
	460-3-60	432	504	125
	575-3-60	540	630	125
240 (20)	208/230-3-60	187	252	125
	460-3-60	432	504	125
	575-3-60	540	630	125

Capacity Performance

XP180/240 Cooling Capacities

XP180 (15 Ton)

Air on Evaporator Coil		Temperature of Air on Condenser Coil															
CFM	WB (°F)	Total Capacity ¹ (MBh)	Total Input (kW) ²	Sensible Capacity (MBh)						Total Capacity ¹ (MBh)	Total Input (kW) ²	Sensible Capacity (MBh)					
				Return Dry Bulb (°F)								Return Dry Bulb (°F)					
				90	85	80	75	70	65			90	85	80	75	70	65
				75°F						85°F							
3750	77	219.4	12.1	99.5	84.2	68.9	-	-	-	206.3	13.4	93.2	78.2	63.2	-	-	-
	72	203.9	11.9	124.1	108.8	93.5	78.2	-	-	192.2	13.2	118.1	103.0	88.0	73.0	-	-
	67	188.4	11.6	148.6	133.3	118.0	102.7	87.4	-	178.0	13.0	142.9	127.9	112.9	97.9	82.9	-
	62	173.3	11.3	173.3	155.4	137.2	121.9	106.6	91.3	163.0	12.7	163.0	152.3	132.0	117.0	102.0	87.0
4500	77	227.7	12.2	111.0	93.3	75.5	-	-	-	213.8	13.5	104.0	86.5	69.1	-	-	-
	72	211.6	11.9	137.9	120.1	102.3	84.5	-	-	199.2	13.2	131.1	113.7	96.3	78.9	-	-
	67	195.6	11.7	164.7	146.9	129.1	111.3	93.5	-	184.5	13.0	158.3	140.9	123.5	106.0	88.6	-
	62	179.8	11.4	179.8	167.9	150.1	132.3	114.5	96.7	169.0	12.8	169.0	161.8	144.4	127.0	109.6	92.2
	57	177.7	11.4	177.7	177.7	163.2	145.4	127.6	109.8	169.0	12.8	169.0	169.0	153.2	135.8	118.4	101.0
5250	77	236.0	12.3	122.5	102.3	82.0	-	-	-	221.3	13.5	114.7	94.9	75.1	-	-	-
	72	219.4	12.0	151.7	131.4	111.1	90.8	-	-	206.2	13.3	144.2	124.4	104.5	84.7	-	-
	67	202.7	11.8	180.8	160.5	140.2	120.0	99.7	-	191.0	13.1	173.7	153.8	134.0	114.2	94.4	-
	62	186.4	11.4	186.4	180.4	163.1	142.8	122.5	102.2	174.9	12.8	174.9	171.3	156.8	136.9	117.1	97.3
	57	184.2	11.5	184.2	184.2	177.3	157.0	136.7	116.4	175.0	12.8	175.0	175.0	166.4	146.5	126.7	106.9
6000	77	244.3	12.3	134.0	111.3	88.5	-	-	-	228.9	13.6	125.4	103.2	81.0	-	-	-
	72	227.1	12.1	165.5	142.7	119.9	97.1	-	-	213.2	13.4	157.2	135.0	112.8	90.6	-	-
	67	209.8	11.9	197.0	174.2	151.4	128.6	105.8	-	197.5	13.2	189.1	166.8	144.6	122.4	100.1	-
	62	193.0	11.5	193.0	193.0	176.0	153.3	130.5	107.7	180.9	12.9	180.9	180.9	169.1	146.9	124.7	102.4
	57	190.7	11.5	190.7	190.7	168.6	145.8	123.0	180.9	180.9	12.9	180.9	180.9	179.5	157.2	135.0	112.8
6750	72	232.3	12.2	175.2	150.5	125.9	101.2	-	-	217.2	13.5	167.1	143.0	119.0	94.9	-	-
	67	214.6	11.9	208.2	183.5	158.8	134.2	109.5	-	201.2	13.2	197.0	176.6	152.5	128.5	104.4	-
	62	197.4	11.6	197.4	197.4	188.9	164.3	139.6	115.0	184.3	13.0	184.3	184.3	178.4	154.3	130.3	106.2
	57	195.1	11.6	195.1	195.1	195.1	170.7	146.1	121.4	184.3	13.0	184.3	184.3	183.6	159.5	135.5	111.4
7500	72	237.5	12.2	184.8	158.3	131.8	105.3	-	-	221.2	13.5	176.9	151.0	125.2	99.3	-	-
	67	219.4	12.0	219.4	192.8	166.3	139.8	113.3	-	204.9	13.3	204.9	186.4	160.5	134.6	108.7	-
	62	201.8	11.7	201.8	201.8	201.8	175.3	148.7	122.2	187.7	13.0	187.7	187.7	187.7	161.8	135.9	110.0
	57	199.4	11.7	199.4	199.4	199.4	172.9	146.4	119.9	187.7	13.0	187.7	187.7	187.7	161.8	135.9	110.0
				95°F						105°F							
3750	77	193.1	14.7	86.9	72.2	57.5	-	-	-	180.1	16.3	79.4	68.4	53.7	-	-	-
	72	180.4	14.5	112.0	97.3	82.6	67.9	-	-	168.7	16.1	107.9	93.1	78.4	63.6	-	-
	67	167.6	14.3	137.2	122.5	107.8	93.1	78.4	-	157.4	16.0	136.3	117.8	103.1	88.3	73.6	-
	62	152.8	14.1	152.8	149.1	126.9	112.2	97.5	82.8	146.4	15.8	146.4	144.6	121.7	106.9	92.2	77.5
4500	77	199.9	14.7	96.9	79.8	62.8	-	-	-	186.2	16.4	93.7	76.4	59.0	-	-	-
	72	186.7	14.6	124.4	107.3	90.3	73.3	-	-	174.5	16.2	120.8	103.5	86.2	68.8	-	-
	67	173.5	14.4	151.9	134.8	117.8	100.8	83.8	-	162.7	16.1	148.0	130.6	113.3	96.0	78.6	-
	62	158.1	14.2	158.1	155.7	138.7	121.6	104.6	87.6	151.4	15.9	151.4	150.2	133.8	116.4	99.1	81.7
	57	160.3	14.1	160.3	160.3	143.2	126.2	109.2	92.2	153.3	15.8	153.3	152.5	135.2	117.9	100.5	83.2
5250	77	206.7	14.8	106.8	87.5	68.1	-	-	-	192.3	16.4	107.9	84.3	64.3	-	-	-
	72	193.0	14.6	136.7	117.3	98.0	78.6	-	-	180.2	16.3	133.8	113.9	93.9	74.0	-	-
	67	179.4	14.5	166.5	147.2	127.8	108.5	89.1	-	168.1	16.2	159.7	143.5	123.5	103.6	83.7	-
	62	163.5	14.2	163.5	162.2	150.4	131.1	111.8	92.4	156.3	15.9	156.3	155.7	145.8	125.9	106.0	86.0
	57	165.7	14.2	165.7	165.7	155.4	136.1	116.7	97.4	158.3	15.9	158.3	157.9	147.4	127.5	107.5	87.6
6000	77	213.4	14.9	116.8	95.1	73.5	-	-	-	198.4	16.5	122.2	92.2	69.7	-	-	-
	72	199.3	14.7	149.0	127.3	105.6	84.0	-	-	185.9	16.4	146.8	124.2	101.7	79.2	-	-
	67	185.2	14.5	181.2	159.5	137.8	116.2	94.5	-	173.4	16.3	171.3	156.3	133.8	111.2	88.7	-
	62	168.8	14.3	168.8	168.8	162.2	140.6	118.9	97.2	161.3	16.0	161.3	161.3	157.9	135.4	112.8	90.3
	57	171.2	14.3	171.2	171.2	167.6	145.9	124.2	102.6	163.3	16.0	163.3	163.3	159.6	137.0	114.5	92.0
6750	72	202.1	14.7	159.0	135.6	112.1	88.6	-	-	188.1	16.4	157.0	132.7	108.3	84.0	-	-
	67	187.8	14.6	185.8	169.7	146.2	122.8	99.3	-	175.4	16.3	174.4	164.3	142.5	118.1	93.7	-
	62	171.2	14.3	171.2	171.2	167.9	144.4	120.9	97.5	163.2	16.0	163.2	163.2	161.5	137.1	112.8	88.4
	57	173.6	14.3	173.6	173.6	171.8	148.3	124.8	101.4	165.3	16.0	165.3	165.3	163.4	139.0	114.7	90.3

XP180 (15 Ton) (Continued)

Air on Evaporator Coil		Temperature of Air on Condenser Coil															
CFM	WB (°F)	Total Capacity ¹ (MBh)	Total Input (kW) ²	Sensible Capacity (MBh)						Total Capacity ¹ (MBh)	Total Input (kW) ²	Sensible Capacity (MBh)					
				Return Dry Bulb (°F)								Return Dry Bulb (°F)					
				90	85	80	75	70	65			90	85	80	75	70	65
7500	72	204.9	14.8	169.1	143.8	118.5	93.3	-	-	190.3	16.4	167.3	141.1	114.9	88.7	-	-
	67	190.4	14.6	190.4	179.9	154.6	129.4	104.1	-	177.5	16.3	177.5	172.2	151.1	125.0	98.8	-
	62	173.5	14.4	173.5	173.5	173.5	148.3	123.0	97.7	165.1	16.1	165.1	165.1	165.1	138.9	112.7	86.5
	57	175.9	14.3	175.9	175.9	175.9	150.7	125.4	100.2	167.2	16.0	167.2	167.2	167.2	141.0	114.8	88.6
115°F										125°F							
3750	77	167.0	17.9	72.0	64.7	49.9	-	-	-	154.0	19.5	63.5	60.8	46.1	-	-	-
	72	157.1	17.8	103.7	88.9	74.1	59.4	-	-	145.5	19.5	99.5	84.7	69.9	55.1	-	-
	67	147.2	17.7	135.4	113.1	98.3	83.6	68.8	-	136.9	19.4	135.0	108.4	93.6	78.8	64.0	-
	62	140.1	17.5	140.1	140.1	116.5	101.7	86.9	72.1	133.7	19.2	133.7	133.7	111.2	96.4	81.6	66.8
4500	77	172.5	18.0	90.5	72.9	55.2	-	-	-	158.7	19.6	87.3	69.4	51.4	-	-	-
	72	162.2	17.9	117.3	99.7	82.0	64.4	-	-	150.0	19.6	113.8	95.8	77.9	59.9	-	-
	67	151.9	17.8	144.1	126.4	108.8	91.1	73.5	-	141.2	19.5	140.2	122.2	104.3	86.3	68.4	-
	62	144.6	17.6	144.6	144.6	128.8	111.2	93.5	75.9	137.9	19.3	137.9	137.9	123.9	106.0	88.0	70.0
57	146.3	17.5	146.3	144.8	127.2	109.5	91.9	74.2	139.2	19.2	139.2	137.1	119.1	101.2	83.2	65.2	
5250	77	177.9	18.1	109.1	81.0	60.5	-	-	-	163.5	19.7	111.2	78.0	56.7	-	-	-
	72	167.3	18.0	130.9	110.4	89.9	69.4	-	-	154.5	19.7	128.1	107.0	85.8	64.7	-	-
	67	156.7	17.9	152.8	139.8	119.2	98.7	78.2	-	145.4	19.6	145.4	136.1	115.0	93.9	72.7	-
	62	149.2	17.7	149.2	149.2	141.2	120.7	100.2	79.6	142.1	19.4	142.1	142.1	136.6	115.5	94.4	73.3
57	150.9	17.6	150.9	150.1	139.4	118.8	98.3	77.8	143.4	19.3	143.4	142.4	131.4	110.2	89.1	68.0	
6000	77	183.3	18.2	127.6	89.2	65.8	-	-	-	168.3	19.8	135.0	86.5	62.0	-	-	-
	72	172.4	18.1	144.6	121.2	97.8	74.4	-	-	159.0	19.7	142.4	118.1	93.8	69.6	-	-
	67	161.5	18.0	161.5	153.1	129.7	106.3	82.9	-	149.7	19.7	149.7	149.7	125.6	101.4	77.1	-
	62	153.7	17.7	153.7	153.7	153.6	130.2	106.8	83.4	146.2	19.5	146.2	146.2	146.2	125.0	100.8	76.5
57	155.5	17.7	155.5	155.5	151.6	128.2	104.8	81.4	147.6	19.4	147.6	147.6	143.6	119.3	95.1	70.8	
6750	72	174.1	18.1	155.0	129.8	104.5	79.3	-	-	160.1	19.7	153.1	126.9	100.8	74.6	-	-
	67	163.1	18.0	163.1	158.9	138.7	113.4	88.2	-	150.7	19.7	150.7	150.7	134.9	108.8	82.6	-
	62	155.2	17.8	155.2	155.2	155.1	129.9	104.6	79.4	147.2	19.5	147.2	147.2	147.2	122.6	96.5	70.3
	57	157.0	17.7	157.0	157.0	155.0	129.8	104.5	79.3	148.7	19.4	148.7	148.7	146.7	120.5	94.4	68.2
7500	72	175.7	18.1	165.5	138.4	111.3	84.2	-	-	161.1	19.7	161.1	135.7	107.7	79.7	-	-
	67	164.6	18.0	164.6	164.6	147.7	120.6	93.4	-	151.7	19.7	151.7	151.7	144.2	116.1	88.1	-
	62	156.7	17.8	156.7	156.7	156.7	129.6	102.5	75.4	148.3	19.5	148.3	148.3	148.3	120.2	92.2	64.2
	57	158.5	17.7	158.5	158.5	158.5	131.3	104.2	77.1	149.7	19.4	149.7	149.7	149.7	121.7	93.6	65.6

1. These capacities are gross ratings. For net capacity, deduct air blower motor, MBh = 3.415 x kW. Refer to the appropriate Blower Performance Table for the kW of the supply air blower motor.
2. These ratings include the condenser fan motors (total ~1.2 kW) and the compressor motors but not the supply air blower motor.

XP240 (20 Ton)

Air on Evaporator Coil		Temperature of Air on Condenser Coil																	
CFM	WB (°F)	Total Capacity ¹ (MBh)	Total Input (kW) ²	Sensible Capacity (MBh)						Total Capacity ¹ (MBh)	Total Input (kW) ²	Sensible Capacity (MBh)							
				Return Dry Bulb (°F)								Return Dry Bulb (°F)							
				90	85	80	75	70	65			90	85	80	75	70	65		
				75°F								85°F							
5000	77	320.4	18.0	120.6	108.4	88.0	67.6	47.2	26.8	315.6	19.7	119.1	104.3	83.7	63.1	42.5	21.9		
	72	298.3	17.6	167.7	147.3	126.9	106.5	86.1	65.7	290.3	19.4	162.9	142.3	121.8	101.2	80.6	60.0		
	67	276.2	17.2	214.8	186.2	165.8	145.4	125.0	104.6	265.0	19.0	206.8	180.4	159.8	139.2	118.7	98.1		
	62	248.0	17.1	223.3	223.2	199.4	179.0	158.7	138.3	239.5	18.8	227.2	208.0	190.3	169.7	149.1	128.5		
6000	77	335.7	18.1	143.5	119.8	96.1	72.4	48.7	25.0	325.8	19.8	138.0	114.6	91.1	67.7	44.2	20.8		
	72	312.4	17.6	186.0	162.3	138.6	114.9	91.2	67.4	299.7	19.4	179.5	156.0	132.6	109.1	85.7	62.2		
	67	289.2	17.2	228.5	204.8	181.1	157.4	133.7	109.9	273.6	19.1	220.9	197.5	174.0	150.6	127.1	103.7		
	62	259.7	17.1	234.1	234.1	217.8	194.1	170.4	146.6	247.3	18.9	234.5	230.6	207.2	183.7	160.3	136.8		
	57	234.1	16.8	234.1	234.1	219.0	195.2	171.5	147.8	234.5	18.7	234.5	234.5	214.3	190.8	167.4	143.9		
7000	77	351.0	18.1	166.5	131.2	104.2	77.2	50.1	23.1	336.1	19.8	156.9	124.9	98.5	72.2	45.9	19.6		
	72	326.6	17.7	204.4	177.3	150.3	123.2	96.2	69.2	309.1	19.5	196.0	169.7	143.4	117.1	90.7	64.4		
	67	302.2	17.3	242.2	223.4	196.4	169.3	142.3	115.2	282.2	19.2	235.1	214.5	188.2	161.9	135.6	109.3		
	62	271.4	17.2	245.0	245.0	236.2	209.1	182.1	155.0	255.0	18.9	241.9	239.9	224.1	197.8	171.5	145.1		
	57	245.0	16.9	245.0	245.0	237.5	210.4	182.7	153.6	241.9	18.8	241.9	241.9	231.8	205.4	178.8	151.5		
8000	77	366.4	18.2	189.5	142.7	112.3	81.9	51.6	21.2	346.3	19.9	175.9	135.1	106.0	76.8	47.6	18.4		
	72	340.8	17.7	222.7	192.3	162.0	131.6	101.2	70.9	318.6	19.6	212.5	183.4	154.2	125.0	95.8	66.6		
	67	315.2	17.3	255.9	242.0	211.6	181.3	150.9	120.5	290.8	19.2	249.2	231.6	202.4	173.2	144.0	114.8		
	62	283.1	17.2	255.9	255.9	254.5	224.1	182.6	153.4	262.8	19.0	249.2	249.2	241.0	211.8	182.6	153.4		
	57	256.0	16.9	255.9	255.9	255.9	225.6	190.2	159.5	249.2	18.8	249.2	249.2	249.2	220.0	190.2	159.0		
8600	72	341.1	17.8	230.3	199.0	167.7	136.4	105.1	73.8	322.4	19.6	221.8	191.3	160.8	130.3	99.8	69.3		
	67	315.6	17.4	255.9	250.4	219.1	187.8	156.5	125.2	294.3	19.3	252.3	241.6	211.1	180.6	150.1	119.6		
	62	283.5	17.3	255.9	255.9	255.9	224.7	186.4	162.1	266.0	19.0	252.3	252.3	248.1	217.6	186.4	156.2		
	57	256.0	17.0	256.0	256.0	256.0	224.7	190.2	159.0	252.3	18.9	252.3	252.3	252.3	221.8	190.2	159.0		
9200	72	341.5	17.9	237.8	205.6	173.4	141.2	108.9	76.7	326.3	19.6	231.1	199.3	167.5	135.7	103.8	72.0		
	67	316.0	17.4	255.9	255.9	226.5	194.3	162.1	129.9	297.9	19.3	255.3	251.7	219.9	188.0	156.2	124.4		
	62	283.8	17.3	255.9	255.9	255.9	223.8	190.2	159.0	269.2	19.0	255.3	255.3	255.3	223.5	190.2	159.0		
	57	256.0	17.0	256.0	256.0	256.0	223.8	190.2	159.0	255.3	18.9	255.3	255.3	255.3	223.5	190.2	159.0		
				95°F								105°F							
5000	77	310.8	21.4	117.6	100.1	79.4	58.6	37.8	17.0	290.2	23.8	108.2	94.0	73.4	52.7	32.1	11.5		
	72	282.3	21.1	158.1	137.4	116.6	95.8	75.0	54.3	264.3	23.5	151.6	131.0	110.4	89.7	69.1	48.5		
	67	253.8	20.9	198.7	174.6	153.8	133.1	112.3	91.5	238.5	23.2	195.0	168.0	147.3	126.7	106.1	85.4		
	62	231.0	20.5	231.0	208.4	181.2	160.4	139.6	118.8	218.2	23.0	218.2	202.5	173.0	152.4	131.7	111.1		
6000	77	316.0	21.5	132.5	109.3	86.1	62.9	39.7	16.6	294.1	23.8	125.5	102.6	79.6	56.7	33.8	10.9		
	72	287.0	21.2	172.9	149.7	126.5	103.3	80.2	57.0	267.9	23.5	165.6	142.7	119.8	96.8	73.9	51.0		
	67	258.0	21.0	213.3	190.1	166.9	143.8	120.6	97.4	241.7	23.3	205.7	182.8	159.9	137.0	114.0	91.1		
	62	234.9	20.6	234.9	219.8	196.6	173.4	150.2	127.0	221.2	23.1	221.2	210.7	187.8	164.8	141.9	119.0		
	57	234.9	20.6	234.9	232.8	209.6	186.4	163.2	140.0	221.2	23.0	221.2	219.2	196.3	173.3	150.4	127.5		
7000	77	321.1	21.6	147.4	118.5	92.9	67.3	41.7	16.1	298.1	23.8	142.7	111.1	85.9	60.7	35.5	10.3		
	72	291.7	21.3	187.6	162.0	136.5	110.9	85.3	59.7	271.5	23.6	179.6	154.4	129.2	104.0	78.8	53.6		
	67	262.2	21.1	227.9	205.6	180.0	154.5	128.9	103.3	244.9	23.3	216.4	197.6	172.4	147.2	122.0	96.8		
	62	238.7	20.7	238.7	231.1	212.0	186.4	160.9	135.3	224.1	23.1	224.1	218.9	202.5	177.3	152.1	126.9		
	57	238.7	20.7	238.7	237.6	226.0	200.5	174.9	149.3	224.1	23.0	224.1	223.1	211.7	186.5	161.3	136.1		
8000	77	326.3	21.7	162.3	127.6	99.6	71.6	43.6	15.7	302.0	23.9	160.0	119.6	92.1	64.7	37.2	9.7		
	72	296.3	21.4	202.4	174.4	146.4	118.4	90.4	62.4	275.1	23.6	193.5	166.1	138.6	111.1	83.6	56.1		
	67	266.4	21.2	242.5	221.1	193.1	165.2	137.2	109.2	248.2	23.3	227.1	212.5	185.0	157.5	130.0	102.5		
	62	242.5	20.8	242.5	242.5	227.5	199.5	171.5	143.5	227.1	23.1	227.1	227.1	217.3	189.8	162.3	134.8		
	57	242.5	20.8	242.5	242.5	242.5	214.5	186.5	158.5	227.1	23.0	227.1	227.1	227.1	199.6	172.1	144.6		
8600	72	303.8	21.4	213.4	183.7	154.0	124.3	94.6	64.9	282.5	23.6	204.4	175.2	145.9	116.7	87.5	58.3		
	67	273.1	21.1	248.6	232.9	203.2	173.5	143.7	114.0	254.9	23.4	233.2	223.4	194.8	165.6	136.4	107.2		
	62	248.6	20.8	248.6	248.6	239.3	209.6	179.8	150.1	233.2	23.1	233.2	233.2	227.4	198.2	168.9	139.7		
	57	248.6	20.7	248.6	248.6	248.6	218.9	188.4	158.8	233.2	23.1	233.2	233.2	233.2	204.0	174.4	145.2		
9200	72	311.2	21.3	224.4	193.0	161.6	130.1	98.7	67.3	289.9	23.6	215.2	184.3	153.3	122.3	91.4	60.4		
	67	279.8	21.1	254.7	244.6	213.2	181.8	150.3	118.9	261.6	23.4	239.3	234.3	204.7	173.7	142.7	111.8		
	62	254.7	20.7	254.7	254.7	251.1	219.6	188.2	156.8	239.3	23.2	239.3	239.3	237.5	206.6	175.6	144.7		
	57	254.7	20.7	254.7	254.7	254.7	223.2	190.2	159.0	239.3	23.1	239.3	239.3	239.3	208.4	176.6	145.8		

XP240 (20 Ton) (Continued)

Air on Evaporator Coil		Temperature of Air on Condenser Coil																	
CFM	WB (°F)	Total Capacity ¹ (MBh)	Total Input (kW) ²	Sensible Capacity (MBh)								Total Capacity ¹ (MBh)	Total Input (kW) ²	Sensible Capacity (MBh)					
				Return Dry Bulb (°F)										Return Dry Bulb (°F)					
				90	85	80	75	70	65	90	85			80	75	70	65		
				115°F								125°F							
5000	77	269.5	26.2	98.8	87.9	67.4	46.9	26.4	-	248.9	28.7	89.5	81.8	61.4	41.1	20.8	-		
	72	246.3	25.9	145.1	124.6	104.1	83.6	63.1	42.6	228.3	28.3	138.6	118.2	97.9	77.5	57.2	36.8		
	67	223.1	25.6	191.3	161.3	140.8	120.3	99.8	79.3	207.8	28.0	187.6	154.6	134.3	114.0	93.6	73.3		
	62	205.4	25.6	205.4	190.0	164.8	144.4	123.9	103.4	192.6	28.1	192.6	189.8	156.2	135.9	115.5	95.3		
6000	77	272.3	26.2	118.5	95.8	73.2	50.5	27.9	-	250.4	28.5	111.5	89.1	66.7	44.3	21.9	-		
	72	248.8	25.9	158.3	135.6	113.0	90.3	67.7	45.0	229.8	28.2	151.0	128.6	106.2	83.8	61.5	39.1		
	67	225.4	25.6	198.1	175.5	152.8	130.2	107.5	84.9	209.1	27.9	190.5	168.1	145.8	123.4	101.0	78.6		
	62	207.5	25.5	207.5	201.6	178.9	156.3	133.6	111.0	193.8	28.0	193.8	192.0	169.6	147.2	124.8	102.5		
7000	77	275.1	26.1	138.1	103.7	78.9	54.1	29.3	-	252.0	28.4	133.5	96.4	71.9	47.5	23.1	-		
	72	251.4	25.8	171.5	146.7	121.9	97.1	72.2	47.4	231.2	28.1	163.4	139.0	114.6	90.1	65.7	41.3		
	67	227.7	25.5	204.9	189.6	164.8	140.0	115.2	90.4	210.4	27.8	193.4	181.7	157.2	132.8	108.4	83.9		
	62	209.6	25.5	209.6	206.6	193.0	168.2	143.3	118.5	195.0	27.9	195.0	194.2	183.0	158.5	134.1	109.7		
8000	77	277.8	26.1	157.7	111.6	84.7	57.7	30.7	-	253.6	28.3	155.5	103.6	77.2	50.7	24.2	-		
	72	253.9	25.8	184.7	157.7	130.8	103.8	76.8	49.8	232.7	28.0	175.9	149.4	122.9	96.5	70.0	43.5		
	67	230.0	25.5	211.7	203.8	176.8	149.9	122.9	95.9	211.7	27.7	196.3	195.2	168.7	142.2	115.7	89.3		
	62	211.7	25.4	211.7	211.7	207.0	180.1	153.1	126.1	196.3	27.7	196.3	196.3	196.3	169.8	143.4	116.9		
8600	72	261.3	25.9	195.4	166.6	137.9	109.1	80.4	51.7	240.0	28.1	186.3	158.1	129.8	101.6	73.3	45.1		
	67	236.7	25.6	217.9	213.9	186.5	157.8	129.0	100.3	218.4	27.8	202.5	202.5	178.2	149.9	121.7	93.4		
	62	217.9	25.5	217.9	217.9	215.5	186.8	158.1	129.3	202.5	27.9	202.5	202.5	202.5	174.3	146.0	117.7		
	57	217.9	25.4	217.9	217.9	217.9	189.1	160.4	131.6	202.5	27.7	202.5	202.5	202.5	174.3	146.4	118.1		
9200	72	268.7	26.0	206.0	175.5	145.0	114.5	84.0	53.5	247.4	28.3	196.8	166.8	136.7	106.7	76.7	46.7		
	67	243.4	25.7	224.0	224.0	196.1	165.6	135.2	104.7	225.1	27.9	208.7	208.7	187.6	157.6	127.6	97.5		
	62	224.0	25.6	224.0	224.0	224.0	193.5	163.0	132.5	208.7	28.0	208.7	208.7	208.7	178.7	148.6	118.6		
	57	224.0	25.4	224.0	224.0	224.0	193.5	163.0	132.5	208.7	27.8	208.7	208.7	208.7	178.7	149.4	119.3		

1. These capacities are gross ratings. For net capacity, deduct air blower motor, MBh = 3.415 x kW. Refer to the appropriate Blower Performance Table for the kW of the supply air blower motor.
2. These ratings include the condenser fan motors (total ~2.5 kW) and the compressor motors but not the supply air blower motor.

XP180/240 Heating Capacities

XP180

Air Over Evaporator Coil		Capacity ¹ & kW	Outdoor Temperature (°F @ 72% RH)							
CFM	DB (°F)		-10	0	10	20	30	40	50	60
4500	55	MBH	46	66	86	106	126	146	167	187
		KW	10.0	10.3	10.6	10.9	11.2	11.5	11.8	12.1
	70	MBH	39	60	80	100	120	140	160	181
KW		11.8	12.1	12.4	12.7	13.0	13.3	13.6	13.9	
80	MBH	35	55	75	95	115	135	156	176	
	KW	13.3	13.6	13.9	14.2	14.5	14.8	15.1	15.3	
5250	55	MBH	48	68	88	109	129	149	169	189
		KW	9.6	9.9	10.2	10.5	10.8	11.0	11.3	11.6
	70	MBH	42	62	82	102	122	143	163	183
KW		11.3	11.6	11.9	12.2	12.5	12.8	13.1	13.4	
80	MBH	37	57	77	97	118	138	158	178	
	KW	12.8	13.1	13.4	13.7	13.9	14.2	14.5	14.8	
6000	55	MBH	50	71	91	111	131	151	171	192
		KW	9.1	9.4	9.7	10.0	10.3	10.6	10.9	11.2
	70	MBH	44	64	85	105	125	145	165	185
KW		10.8	11.1	11.4	11.7	12.0	12.3	12.6	12.9	
80	MBH	39	60	80	100	120	140	160	181	
	KW	12.2	12.5	12.8	13.1	13.4	13.7	14.0	14.3	
6750	55	MBH	51	72	92	112	132	152	172	192
		KW	8.8	9.1	9.4	9.7	10.0	10.3	10.6	10.9
	70	MBH	45	65	85	106	126	146	166	186
KW		10.6	10.9	11.2	11.5	11.7	12.0	12.3	12.6	
80	MBH	40	61	81	101	121	141	161	181	
	KW	12.0	12.3	12.6	12.9	13.2	13.5	13.8	14.1	
7500	55	MBH	52	72	93	113	133	153	173	193
		KW	8.5	8.8	9.1	9.4	9.7	10.0	10.3	10.6
	70	MBH	46	66	86	107	127	147	167	187
KW		10.3	10.6	10.9	11.2	11.5	11.8	12.1	12.4	
80	MBH	41	61	82	102	122	142	162	182	
	KW	11.8	12.1	12.4	12.7	12.9	13.2	13.5	13.8	

1. These capacities do not include the supply air blower motor heat. For net capacity, add motor heat, MBh = 3.415 x kW.

XP240

Air Over Evaporator Coil		Capacity ¹ & kW	Outdoor Temperature (°F @ 72% RH)							
CFM	DB (°F)		-10	0	10	20	30	40	50	60
6000	55	MBH	63	98	134	169	204	239	275	310
		KW	14.9	15.6	16.2	16.8	17.4	18.1	18.7	19.3
	70	MBH	55	91	126	161	196	231	267	302
KW		17.4	18.0	18.6	19.3	19.9	20.5	21.1	21.8	
80	MBH	48	83	119	154	189	224	259	295	
	KW	19.2	19.8	20.5	21.1	21.7	22.3	23.0	23.6	
7000	55	MBH	65	100	136	171	206	241	277	312
		KW	14.1	14.7	15.4	16.0	16.6	17.2	17.9	18.5
	70	MBH	57	92	128	163	198	233	269	304
KW		16.5	17.2	17.8	18.4	19.1	19.7	20.3	20.9	
80	MBH	50	85	120	156	191	226	261	297	
	KW	18.4	19.0	19.6	20.3	20.9	21.5	22.2	22.8	
8000	55	MBH	67	102	138	173	208	243	278	314
		KW	13.3	13.9	14.5	15.2	15.8	16.4	17.0	17.7
	70	MBH	59	94	130	165	200	235	271	306
KW		15.7	16.4	17.0	17.6	18.2	18.9	19.5	20.1	
80	MBH	52	87	122	158	193	228	263	298	
	KW	17.6	18.2	18.8	19.4	20.1	20.7	21.3	22.0	
8600	55	MBH	67	102	138	173	208	243	279	314
		KW	13.0	13.6	14.2	14.9	15.5	16.1	16.7	17.4
	70	MBH	59	95	130	165	200	235	271	306
KW		15.4	16.1	16.7	17.3	17.9	18.6	19.2	19.8	
80	MBH	52	87	123	158	193	228	263	299	
	KW	17.3	17.9	18.5	19.1	19.8	20.4	21.0	21.7	
9200	55	MBH	67	103	138	173	208	243	279	314
		KW	12.7	13.3	13.9	14.6	15.2	15.8	16.5	17.1
	70	MBH	59	95	130	165	200	236	271	306
KW		15.1	15.7	16.4	17.0	17.6	18.3	18.9	19.5	
80	MBH	52	87	123	158	193	228	264	299	
	KW	16.9	17.6	18.2	18.8	19.5	20.1	20.7	21.3	

1. These capacities do not include the supply air blower motor heat. For net capacity, add motor heat, MBh = 3.415 x kW.

XP180/240 Bottom Duct Application

XP180 (15 Ton) Bottom Duct

Air Flow (CFM)	Available External Static Pressure - IWG ¹																									
	0.4		0.6		0.8		1.0		1.2		1.4		1.6		1.8		2.0		2.2		2.4		2.6			
	RPM	BHP	RPM	BHP	RPM	BHP	RPM	BHP	RPM	BHP	RPM	BHP	RPM	BHP	RPM	BHP	RPM	BHP	RPM	BHP	RPM	BHP	RPM	BHP	RPM	BHP
	Standard 5 HP & Field Supplied Drive				Standard 5 HP & Drive								High Static 7.5 HP & Drive													
4000	642	0.25	676	0.72	711	1.14	746	1.52	782	1.87	818	2.19	853	2.49	887	2.79	920	3.08	951	3.38	980	3.69	1006	4.02		
4400	659	0.59	693	1.06	728	1.48	763	1.86	799	2.21	835	2.53	870	2.83	904	3.13	937	3.42	968	3.71	997	4.03	1023	4.36		
4800	678	0.95	712	1.43	746	1.85	782	2.23	818	2.58	854	2.90	889	3.20	923	3.49	956	3.78	987	4.08	1016	4.39	1042	4.73		
5200	699	1.36	732	1.83	767	2.25	803	2.63	839	2.98	874	3.30	910	3.60	944	3.90	977	4.19	1008	4.48	1036	4.80	1062	5.13		
5600	721	1.80	755	2.28	790	2.70	825	3.08	861	3.43	897	3.75	932	4.05	966	4.34	999	4.63	1030	4.93	1059	5.24	1085	5.58		
6000	745	2.30	779	2.77	814	3.19	849	3.57	885	3.92	921	4.24	956	4.54	990	4.83	1023	5.12	1054	5.42	1083	5.73	1109	6.07		
6400	770	2.83	804	3.31	839	3.73	874	4.11	910	4.46	946	4.78	981	5.08	1015	5.37	1048	5.66	1079	5.96	1108	6.27	1134	6.61		
6800	797	3.42	830	3.89	865	4.31	901	4.70	936	5.04	972	5.36	1007	5.66	1042	5.96	1074	6.25	1105	6.55	1134	6.86	1160	7.19		
7200	824	4.05	857	4.53	892	4.95	928	5.33	964	5.68	999	6.00	1035	6.30	1069	6.59	1102	6.88	1133	7.18	1161	7.49	-	-		
7600	852	4.73	885	5.21	920	5.63	956	6.01	992	6.36	1027	6.68	1063	6.98	1097	7.27	1130	7.56	-	-	-	-	-	-		

7.5 HP & Field Supplied Drive

1. Blower performance includes 2" filters only. See STATIC RESISTANCE table for additional applications.
2. See RPM SELECTION table to determine required motor sheave setting.
3. kW = BHP x 0.834.

XP240 (20 Ton) Bottom Duct

Air Flow (CFM)	Available External Static Pressure - IWG ¹																									
	0.4		0.6		0.8		1.0		1.2		1.4		1.6		1.8		2.0		2.2		2.4		2.6			
	RPM	BHP	RPM	BHP	RPM	BHP	RPM	BHP	RPM	BHP	RPM	BHP	RPM	BHP	RPM	BHP	RPM	BHP	RPM	BHP	RPM	BHP	RPM	BHP	RPM	BHP
	Standard 7.5 HP & Field Supplied Drive				Standard 7.5 HP & Drive								High Static 10 HP & Drive													
5200	660	1.45	695	1.93	730	2.39	765	2.82	800	3.24	836	3.65	870	4.04	904	4.42	937	4.79	968	5.15	998	5.51	1026	5.87		
5600	686	1.78	720	2.26	755	2.72	791	3.16	826	3.58	861	3.98	896	4.37	930	4.75	963	5.12	994	5.49	1024	5.85	1052	6.20		
6000	711	2.19	746	2.67	781	3.13	816	3.57	851	3.99	887	4.39	921	4.78	955	5.16	988	5.54	1019	5.90	1049	6.26	1077	6.61		
6400	736	2.68	771	3.16	806	3.62	841	4.06	876	4.48	912	4.88	946	5.27	980	5.65	1013	6.02	1044	6.39	1074	6.75	1102	7.10		
6800	761	3.24	796	3.72	831	4.18	867	4.62	902	5.04	937	5.44	972	5.83	1005	6.21	1038	6.58	1070	6.95	1100	7.31	1128	7.66		
7200	787	3.87	822	4.35	857	4.81	893	5.25	928	5.67	963	6.07	998	6.46	1031	6.84	1064	7.21	1096	7.58	1126	7.94	1154	8.29		
7600	814	4.57	849	5.05	884	5.51	919	5.95	955	6.37	990	6.77	1024	7.16	1058	7.54	1091	7.91	1123	8.28	1152	8.63	1180	8.99		
8000	842	5.33	877	5.81	912	6.27	947	6.71	982	7.13	1018	7.53	1052	7.92	1086	8.30	1119	8.67	1150	9.04	1180	9.40	-	-		
8400	871	6.16	905	6.64	941	7.09	976	7.53	1011	7.95	1046	8.36	1081	8.75	1115	9.13	1148	9.50	1179	9.86	-	-	-	-		
8800	901	7.04	936	7.52	971	7.97	1006	8.41	1041	8.83	1076	9.24	1111	9.63	1145	10.01	-	-	-	-	-	-	-	-		
9200	932	7.98	967	8.45	1002	8.91	1037	9.35	1073	9.77	-	-	-	-	-	-	-	-	-	-	-	-	-	-		
9600	965	8.97	999	9.45	1034	9.90	-	-	-	-	-	-	-	-	-	-	-	-	-	-	-	-	-	-		
10000	999	10.01	-	-	-	-	-	-	-	-	-	-	-	-	-	-	-	-	-	-	-	-	-	-		

1. Blower performance includes 2" filters only. See STATIC RESISTANCE table for additional applications.
2. See RPM SELECTION table to determine required motor sheave setting.
3. kW = BHP x 0.820.

RPM Selection

Size (Tons)	Model	HP	Motor Sheave	Blower Sheave	6 Turns Open	5 Turns Open	4 Turns Open	3 Turns Open	2 Turns Open	1 Turns Open	Fully Closed
180 (15)	XP	5	1VP60	BK120	700	730	760	790	820	850	880
		7.5	1VP60	BK100	845	885	925	960	1000	1035	1070
240 (20)	XP	7.5	1VP60	BK110	765	800	835	870	900	935	965
		10	1VP60	BK090	930	970	1010	1050	1090	1130	1170

Additional Static Resistance

Size (Tons)	Model	CFM	Economizer ^{1, 2}	Electric Heat kW ¹			
				18	36	54	72
180 (15)	XP	4500	0.10	0.10	0.10	0.20	0.20
		6000	0.10	0.10	0.10	0.20	0.20
		7500	0.10	0.10	0.20	0.30	0.40
6000		0.10	0.10	0.10	0.20	0.20	
7500		0.10	0.10	0.20	0.30	0.40	
9000		0.15	0.10	0.30	0.40	0.60	
10000		0.15	0.15	0.35	0.55	0.75	

1. Deduct these values from the available external static pressure shown in the respective Blower Performance Tables.
2. The pressure drop through the economizer is greater for 100% outdoor air than for 100% return air. If the resistance of the return air duct is less than 0.25 IWG, the unit will deliver less CFM during full economizer operations.

Drive Selection

1. Determine side or bottom supply duct application.
2. Determine desired airflow
3. Calculate or measure the amount of external static pressure.
4. Using the operating point determined from steps 1, 2 & 3, locate this point on the appropriate supply air blower performance table. (Linear interpolation may be necessary.)
5. Noting the RPM and BHP from step 4, locate the appropriate motor and/or drive on the RPM selection table.
6. Review the BHP compared to the motor options available. Select the appropriate motor and/or drive.
7. Review the RPM range for the motor options available. Select the appropriate drive if multiple drives are available for the chosen motor.
8. Determine turns open to obtain the desired operation point.

Example

1. 6800 CFM
2. 2.0 iwg
3. Using the supply air blower performance table below, the following data point was located: 1020 RPM & 5.92 BHP.
4. Using the RPM selection table below, Size X and Model Y is found.
5. 5.92 BHP exceeds the maximum continuous BHP rating of the 5.0 HP motor. The 7.5 HP motor is required.
6. 1020 RPM is within the range of the 7.5 HP drives.
7. Using the 7.5 HP motor and drive, 3.5 turns open will achieve 1020 RPM.

Example Supply Air Blower Performance

Air Flow (CFM)	Available External Static Pressure - IWG																							
	0.4		0.6		0.8		1.0		1.2		1.4		1.6		1.8		2.0		2.2		2.4		2.6	
	RPM	BHP	RPM	BHP	RPM	BHP	RPM	BHP	RPM	BHP	RPM	BHP	RPM	BHP	RPM	BHP	RPM	BHP	RPM	BHP	RPM	BHP	RPM	BHP
	Standard 5 HP & Field Supplied Drive		Standard 5 HP & Drive										High Static 7.5 HP & Drive											
6400	719	2.55	756	3.03	792	3.49	828	3.92	864	4.32	899	4.67	933	4.98	966	5.24	998	5.45	1028	5.59	1056	5.67	1083	5.68
6800	742	3.02	778	3.51	814	3.97	850	4.40	886	4.79	921	5.15	955	5.46	988	5.72	1020	5.92	1050	6.07	1078	6.15	1105	6.16
7200	765	3.54	802	4.03	838	4.49	874	4.92	910	5.32	945	5.67	979	5.98	1012	6.24	1044	6.44	1074	6.59	1102	6.67	1129	6.68
7600	790	4.11	827	4.60	863	5.06	899	5.49	935	5.88	970	6.24	1004	6.55	1037	6.81	1069	7.01	1099	7.16	1127	7.24	1154	7.25
																					7.5 HP & Field Supplied Drive			

Table X: RPM Selection

Size (Tons)	Model	HP	Max BHP	Motor Sheave	Blower Sheave	6 Turns Open	5 Turns Open	4 Turns Open	3 Turns Open	2 Turns Open	1 Turn Open	Fully Closed
X	Y	5	5.75	1VP60	BK110	730	765	800	835	870	905	N/A
		7.5	8.63	1VP60	BK090	905	950	990	1035	1075	1120	N/A

Altitude/Temperature Correction Factors

Air Temp.	Altitude (Ft.)										
	0	1000	2000	3000	4000	5000	6000	7000	8000	9000	10000
40	1.060	1.022	0.986	0.950	0.916	0.882	0.849	0.818	0.788	0.758	0.729
50	1.039	1.002	0.966	0.931	0.898	0.864	0.832	0.802	0.772	0.743	0.715
60	1.019	0.982	0.948	0.913	0.880	0.848	0.816	0.787	0.757	0.729	0.701
70	1.000	0.964	0.930	0.896	0.864	0.832	0.801	0.772	0.743	0.715	0.688
80	0.982	0.947	0.913	0.880	0.848	0.817	0.787	0.758	0.730	0.702	0.676
90	0.964	0.929	0.897	0.864	0.833	0.802	0.772	0.744	0.716	0.689	0.663
100	0.946	0.912	0.880	0.848	0.817	0.787	0.758	0.730	0.703	0.676	0.651

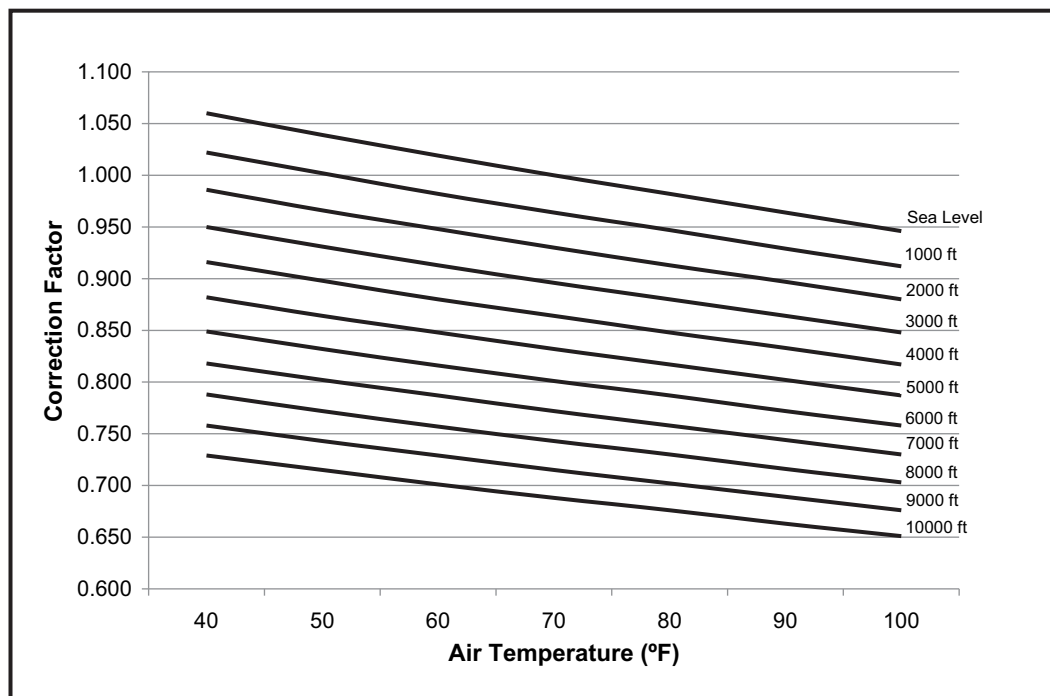

Electric Heat Minimum Supply Air

Size (Tons)	Voltage	Minimum Supply Air (CFM)			
		Heater kW			
		18	36	54	72
180 (15)	208/230-3-60	4500	4500	5000	5000
	460-3-60	4500	4500	5000	5000
	600-3-60	4500	4500	4500	4500
240 (20)	208/230-3-60	6000	6000	6000	6000
	460-3-60	6000	6000	6000	6000
	600-3-60	6000	6000	6000	6000

Indoor Blower Specifications

Size (Tons)	Model	Motor					Motor Sheave			Blower Sheave			Belt
		HP	RPM	Eff.	SF	Frame	Datum Dia.	Bore (in)	Model	Datum Dia.	Bore (in)	Model	
180 (15)	XP	5	1750	0.895	1.15	184T	4.5 - 5.7	1-1/8	1VP60	11.4	1-3/16	BK120	BX81
		7.5	1750	0.91	1.15	213T	4.5 - 5.7	1-3/8	1VP60	9.4	1-3/16	BK100	BX78
240 (20)	XP	7.5	1750	0.91	1.15	213T	4.5 - 5.7	1-3/8	1VP60	10.4	1-3/16	BK110	BX78
		10	1760	0.895	1.15	215T	4.5 - 5.7	1-3/8	1VP60	8.4	1-3/16	BK090	BX75

Power Exhaust Specifications

Voltage	Motor			Motor			CFM @ 0.2 ESP
	HP	RPM ¹	QTY	LRA	FLA	MCA	
208/230-1-60	3/4	1075	1	7.7	5.0	6.25	5250
460-1-60	3/4	1075	1	4.1	2.2	2.75	5250
575-1-60	3/4	1050	1	2.84	1.5	1.875	5250

1. Motors are multi-tapped and factory wired for high speed.

Electric Heat Multipliers

Voltage		kW Capacity Multipliers ¹
Nominal	Applied	
240	208	0.75
	230	0.92
480	460	0.92
600	575	0.92

1. Electric heaters are rated at nominal voltage. Use this table to determine the electric heat capacity for heaters applied at lower voltages.

Sound Performance

XP Indoor Sound Power Levels

Size (Tons)	CFM	ESP (IWG)	Blower		Sound Power, dB (10 ⁻¹²) Watts								
					Sound Rating ¹ dB (A)	Octave Band Centerline Frequency (Hz)							
			RPM	BHP		63	125	250	500	1000	2000	4000	8000
180 (15)	6000	1.0	1080	4.60	89	99	99	89	82	84	77	72	67
240 (20)	8000	1.0	1120	6.65	92	102	102	92	85	87	80	75	70

1. These values have been accessed using a model of sound propagation from a point source into the hemispheric/free field. The dBA values provided are to be used for reference only. Calculation of dBA values cover matters of system design and the fan manufacture has no way of knowing the details of each system. This constitutes an exception to any specification or guarantee requiring a dBA value of sound data in any other form than sound power level ratings.

XP Outdoor Sound Power Levels

Size (Tons)	Sound Rating ¹ dB (A)	Sound Power, dB (10 ⁻¹²) Watts							
		Octave Band Centerline Frequency (Hz)							
		63	125	250	500	1000	2000	4000	8000
180 (15)	92	90	93	91	89	86	83	80	75
240 (20)	92	91	94	92	89	87	83	81	76

1. Rated in accordance with AHRI 270 standard.

Electrical Data

XP180/240

XP180/240 - Standard Drive Without Powered Convenience Outlet

Size (Tons)	Volt	Compressors (each)			OD Fan Motors (each)	Supply Blower Motor	Pwr Conv Outlet	Electric Heat (Field Installed Accessory Only)				MCA ¹ (Amps)	Max Fuse ² / Breaker ³ Size (Amps)
		RLA	LRA	MCC	FLA	FLA	FLA	Model	kW	Stages	Amps		
180 (15)	208-3-60	25	164	39	4.1	13.5	0	NONE	-	-	-	78	100
								E18	13.5	1	37.5	124.8	125
								E36	27	2	74.9	124.8	125
								E54	40.6	2	112.7	157.7	175
								E72	54.1	2	150.2	171.6	200
	230-3-60	25	164	39	3.9	13	0	NONE	-	-	-	77.1	100
								E18	18	1	43.3	131.2	150
								E36	36	2	86.6	131.2	150
								E54	54	2	129.9	146.2	175
								E72	72	2	173.2	189.5	225
	460-3-60	12.2	100	19	2.15	6.5	0	NONE	-	-	-	38.3	50
								E18	18	1	21.7	65.3	70
								E36	36	2	43.3	65.3	70
								E54	54	2	65	73.1	80
								E72	72	2	86.6	94.7	110
	575-3-60	9	78	14	1.6	5.2	0	NONE	-	-	-	28.7	35
								E18	18	1	17.3	50.3	60
								E36	36	2	34.6	50.3	60
								E54	54	2	52	58.5	70
								E72	72	2	69.3	75.8	90
240 (20)	208-3-60	34.3	239	52	3.5	20	0	NONE	-	-	-	111.2	125
								E18	13.5	1	37.5	158	175
								E36	27	2	74.9	158	175
								E54	40.6	2	112.7	165.9	175
								E72	54.1	2	150.2	204.9	225
	230-3-60	34.3	239	52	3.5	19.4	0	NONE	-	-	-	110.6	125
								E18	18	1	43.3	164.7	175
								E36	36	2	86.6	164.7	175
								E54	54	2	129.9	164.7	175
								E72	72	2	173.2	218.8	225
	460-3-60	17.9	125	28	1.9	9.7	0	NONE	-	-	-	57.6	70
								E18	18	1	21.7	84.6	90
								E36	36	2	43.3	84.6	90
								E54	54	2	65	84.6	90
								E72	72	2	86.6	111.7	125
	575-3-60	12.8	80	20	1.5	7.8	0	NONE	-	-	-	42.6	50
								E18	18	1	17.3	64.3	70
								E36	36	2	34.6	64.3	70
								E54	54	2	52	64.3	70
								E72	72	2	69.3	85.9	90

1. Minimum Circuit Ampacity.
2. Dual Element, Time Delay Type.
3. HACR type per NEC.

XP180/240 - Standard Drive With Powered Convenience Outlet

Size (Tons)	Volt	Compressors (each)			OD Fan Motors (each)	Supply Blower Motor	Pwr Conv Outlet	Electric Heat (Field Installed Accessory Only)				MCA ¹ (Amps)	Max Fuse ² / Breaker ³ Size (Amps)
		RLA	LRA	MCC	FLA	FLA	FLA	Model	kW	Stages	Amps		
180 (15)	208-3-60	25	164	39	4.1	13.5	10	NONE	-	-	-	88	110
								E18	13.5	1	37.5	134.8	150
								E36	27	2	74.9	134.8	150
								E54	40.6	2	112.7	170.2	175
								E72	54.1	2	150.2	181.6	200
	230-3-60	25	164	39	3.9	13	10	NONE	-	-	-	87.1	110
								E18	18	1	43.3	141.2	150
								E36	36	2	86.6	141.2	150
								E54	54	2	129.9	158.7	175
								E72	72	2	173.2	202	225
	460-3-60	12.2	100	19	2.15	6.5	5	NONE	-	-	-	43.3	50
								E18	18	1	21.7	70.3	80
								E36	36	2	43.3	70.3	80
								E54	54	2	65	79.3	90
								E72	72	2	86.6	101	110
	575-3-60	9	78	14	1.6	5.2	4	NONE	-	-	-	32.7	40
								E18	18	1	17.3	54.3	60
								E36	36	2	34.6	54.8	60
								E54	54	2	52	63.5	70
								E72	72	2	69.3	80.8	90
240 (20)	208-3-60	34.3	239	52	3.5	20	10	NONE	-	-	-	121.2	150
								E18	13.5	1	37.5	168	175
								E36	27	2	74.9	168	175
								E54	40.6	2	112.7	178.4	200
								E72	54.1	2	150.2	214.9	225
	230-3-60	34.3	239	52	3.5	19.4	10	NONE	-	-	-	120.6	150
								E18	18	1	43.3	174.7	175
								E36	36	2	86.6	174.7	175
								E54	54	2	129.9	174.7	175
								E72	72	2	173.2	228.8	250
	460-3-60	17.9	125	28	1.9	9.7	5	NONE	-	-	-	62.6	80
								E18	18	1	21.7	89.6	100
								E36	36	2	43.3	89.6	100
								E54	54	2	65	89.6	100
								E72	72	2	86.6	116.7	125
	575-3-60	12.8	80	20	1.5	7.8	4	NONE	-	-	-	46.6	50
								E18	18	1	17.3	68.3	70
								E36	36	2	34.6	68.3	70
								E54	54	2	52	68.3	70
								E72	72	2	69.3	89.9	90

1. Minimum Circuit Ampacity.
2. Dual Element, Time Delay Type.
3. HACR type per NEC.

XP180/240 - High Static Drive Without Powered Convenience Outlet

Size (Tons)	Volt	Compressors (each)			OD Fan Motors (each)	Supply Blower Motor	Pwr Conv Outlet	Electric Heat (Field Installed Accessory Only)				MCA ¹ (Amps)	Max Fuse ^{2/} Breaker ³ Size (Amps)
		RLA	LRA	MCC	FLA	FLA	FLA	Model	kW	Stages	Amps		
180 (15)	208-3-60	25	164	39	4.1	20	0	NONE	-	-	-	84.5	100
								E18	13.5	1	37.5	131.3	150
								E36	27	2	74.9	131.3	150
								E54	40.6	2	112.7	165.9	175
	230-3-60	25	164	39	3.9	19.4	0	NONE	-	-	-	83.5	100
								E18	18	1	43.3	137.6	150
								E36	36	2	86.6	137.6	150
								E54	54	2	129.9	154.2	175
	460-3-60	12.2	100	19	2.15	9.7	0	NONE	-	-	-	41.5	50
								E18	18	1	21.7	68.5	70
								E36	36	2	43.3	68.5	70
								E54	54	2	65	77.1	90
	575-3-60	9	78	14	1.6	7.8	0	NONE	-	-	-	31.3	40
								E18	18	1	17.3	52.9	60
								E36	36	2	34.6	53.1	60
								E54	54	2	52	61.7	70
240 (20)	208-3-60	34.3	239	52	3.5	26	0	NONE	-	-	-	117.2	150
								E18	13.5	1	37.5	164	175
								E36	27	2	74.9	164	175
								E54	40.6	2	112.7	173.4	175
	230-3-60	34.3	239	52	3.5	25	0	NONE	-	-	-	116.2	150
								E18	18	1	43.3	170.3	175
								E36	36	2	86.6	170.3	175
								E54	54	2	129.9	170.3	175
	460-3-60	17.9	125	28	1.9	12.5	0	NONE	-	-	-	60.4	70
								E18	18	1	21.7	87.4	90
								E36	36	2	43.3	87.4	90
								E54	54	2	65	87.4	90
	575-3-60	12.8	80	20	1.5	10	0	NONE	-	-	-	44.8	50
								E18	18	1	17.3	66.5	70
								E36	36	2	34.6	66.5	70
								E54	54	2	52	66.5	70
							NONE	-	-	-	88.1	90	
							E18	18	1	17.3	66.5	70	
							E36	36	2	34.6	66.5	70	
							E54	54	2	52	66.5	70	
							NONE	-	-	-	88.1	90	
							E18	18	1	17.3	66.5	70	
							E36	36	2	34.6	66.5	70	
							E54	54	2	52	66.5	70	

1. Minimum Circuit Ampacity.
2. Dual Element, Time Delay Type.
3. HACR type per NEC.

XP180/240 - High Static Drive With Powered Convenience Outlet

Size (Tons)	Volt	Compressors (each)			OD Fan Motors (each)	Supply Blower Motor	Pwr Conv Outlet	Electric Heat (Field Installed Accessory Only)				MCA ¹ (Amps)	Max Fuse ^{2/} Breaker ³ Size (Amps)
		RLA	LRA	MCC	FLA	FLA	FLA	Model	kW	Stages	Amps		
180 (15)	208-3-60	25	164	39	4.1	20	10	NONE	-	-	-	94.5	110
								E18	13.5	1	37.5	141.3	150
								E36	27	2	74.9	141.3	150
								E54	40.6	2	112.7	178.4	200
	230-3-60	25	164	39	3.9	19.4	10	NONE	-	-	-	93.5	110
								E18	18	1	43.3	147.6	150
								E36	36	2	86.6	147.6	150
								E54	54	2	129.9	166.7	175
	460-3-60	12.2	100	19	2.15	9.7	5	NONE	-	-	-	46.5	50
								E18	18	1	21.7	73.5	80
								E36	36	2	43.3	73.5	80
								E54	54	2	65	83.3	90
	575-3-60	9	78	14	1.6	7.8	4	NONE	-	-	-	35.3	40
								E18	18	1	17.3	56.9	60
								E36	36	2	34.6	58.1	60
								E54	54	2	52	66.7	70
240 (20)	208-3-60	34.3	239	52	3.5	26	10	NONE	-	-	-	127.2	150
								E18	13.5	1	37.5	174	175
								E36	27	2	74.9	174	175
								E54	40.6	2	112.7	185.9	200
	230-3-60	34.3	239	52	3.5	25	10	NONE	-	-	-	126.2	150
								E18	18	1	43.3	180.3	200
								E36	36	2	86.6	180.3	200
								E54	54	2	129.9	180.3	200
	460-3-60	17.9	125	28	1.9	12.5	5	NONE	-	-	-	65.4	80
								E18	18	1	21.7	92.4	100
								E36	36	2	43.3	92.4	100
								E54	54	2	65	92.4	100
	575-3-60	12.8	80	20	1.5	10	4	NONE	-	-	-	48.8	60
								E18	18	1	17.3	70.5	80
								E36	36	2	34.6	70.5	80
								E54	54	2	52	70.5	80
							NONE	-	-	-	92.1	100	
							E18	18	1	17.3	70.5	80	
							E36	36	2	34.6	70.5	80	
							E54	54	2	52	70.5	80	
							NONE	-	-	-	92.1	100	
							E18	18	1	17.3	70.5	80	
							E36	36	2	34.6	70.5	80	
							E54	54	2	52	70.5	80	

1. Minimum Circuit Ampacity.
2. Dual Element, Time Delay Type.
3. HACR type per NEC.

XP180/240 Wiring Diagrams

XP180/240 Typical Control Diagram

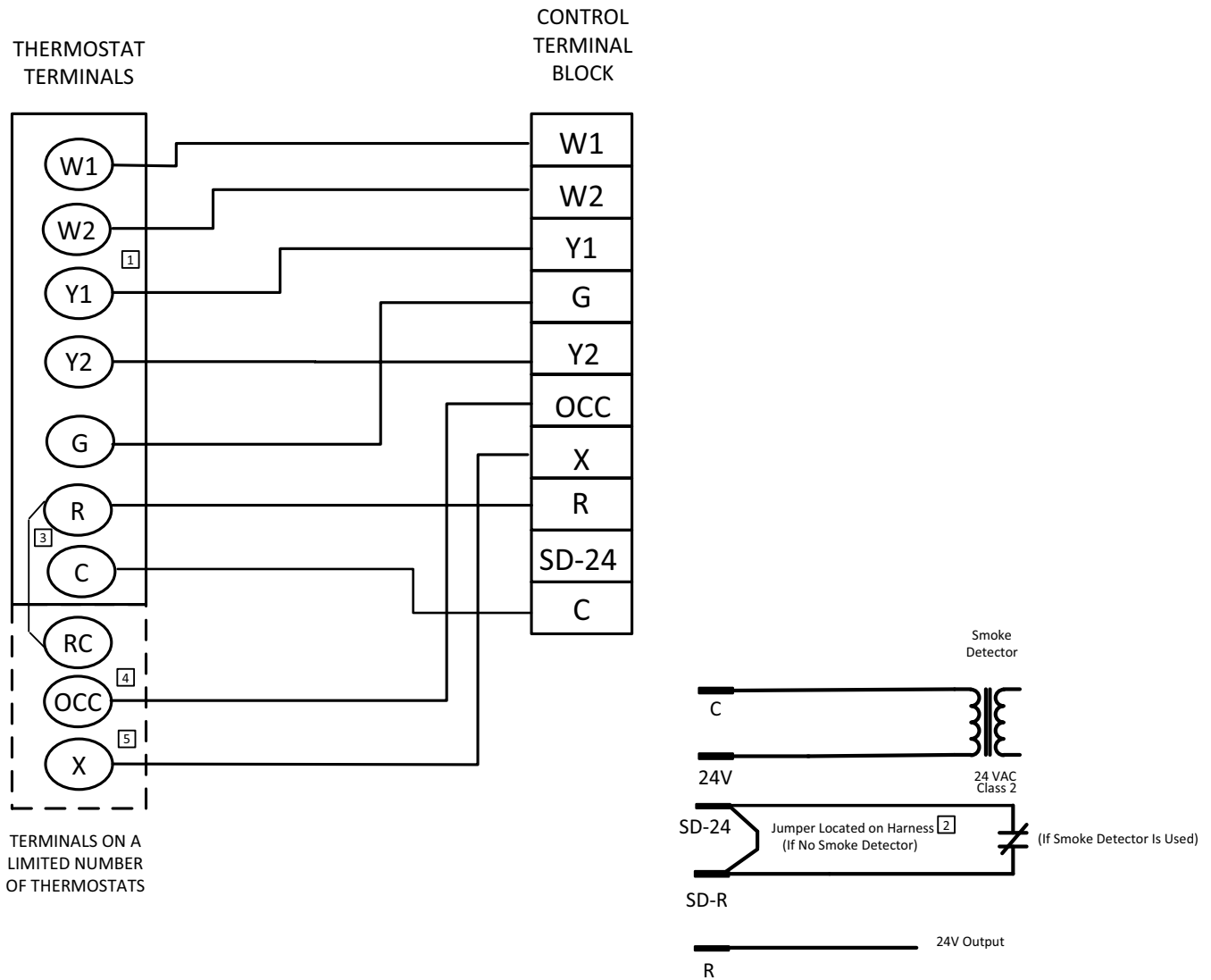

- 1 Second stage heating not required on single stage heating units.
- 2 Jumper is required if there is no Smoke Detector circuit.
- 3 Jumper is required for any combination of R, RC, or RH.
- 4 OCC is an output from the thermostat to indicate the Occupied condition.
- 5 X is an input to the thermostat to display Error Status conditions.

Weights and Dimensions

XP240 Unit 4 Point Load Weight

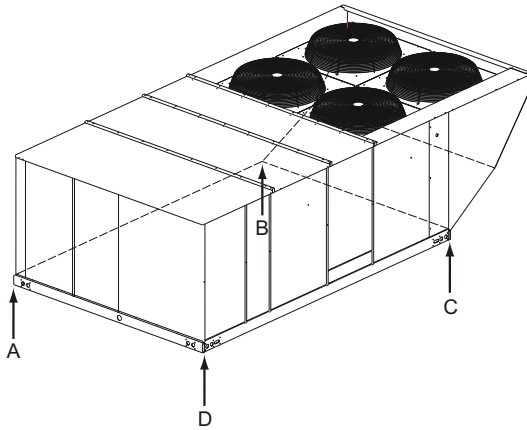

XP240 Unit 6 Point Load Weight

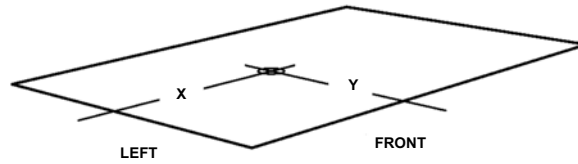
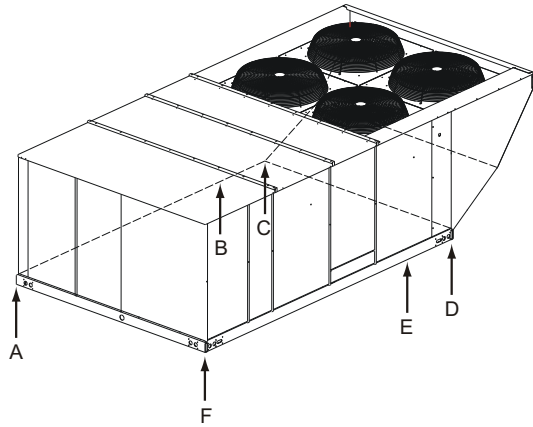

XP180 Unit 4 Point Load Weight

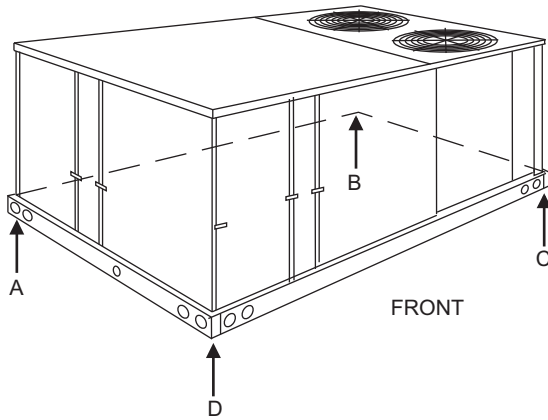

XP180 Unit 6 Point Load Weight

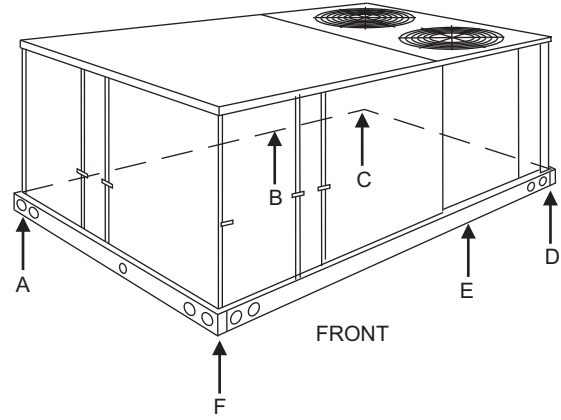

XP180/240 Unit Weights

Size (Tons)	Model	Weight (lbs.)		Center of Gravity		4 Point Load Location (lbs.)				6 Point Load Location (lbs.)					
		Shipping	Operating	X	Y	A	B	C	D	A	B	C	D	E	F
180 (15)	XP	2145	2140	77.1	45	454	592	619	475	290	344	413	431	359	303
240 (20)	XP	2655	2650	88.8	46	462	863	863	462	280	405	640	640	405	280

XP180/240 Unit Accessory Weights

Unit Accessory	Weight (lbs.)	
	Shipping	Operating
Economizer	165	160
Power Exhaust	90	85
Electric Heat ¹	40	40
Double Wall ²	260	260
Motorized Damper	150	150
Barometric Damper	50	45
Econ./Motorized Damper Rain Hood	60	55
Econ./Power Exhaust Rain Hood	95	90
Wood Skid	220	220
Roof Curb	190	185

1. Weight given is for the maximum heater size available (72KW).
2. Available on XP240 only.

Unit Dimensions

XP240 Unit Dimensions Front View

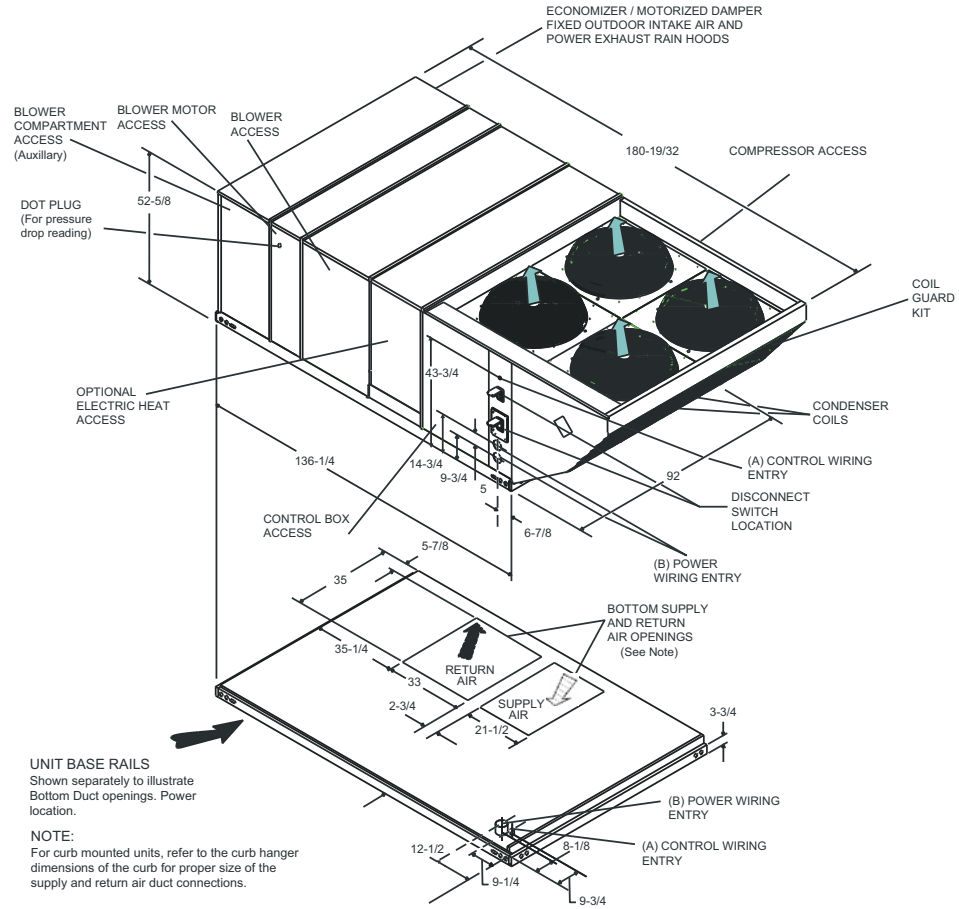

Utilities Entry

Hole	Opening Size Diameter	Used For	
A	1-1/8" KO	Control Wiring	Front
	3/4" NPS (Fem.)		Bottom
B	3-5/8" KO	Power Wiring	Front
	3" NPS (Fem.)		Bottom

NOTE: All entry holes should be field sealed to prevent rain water entry into the building.

XP180 Unit Dimensions Front View

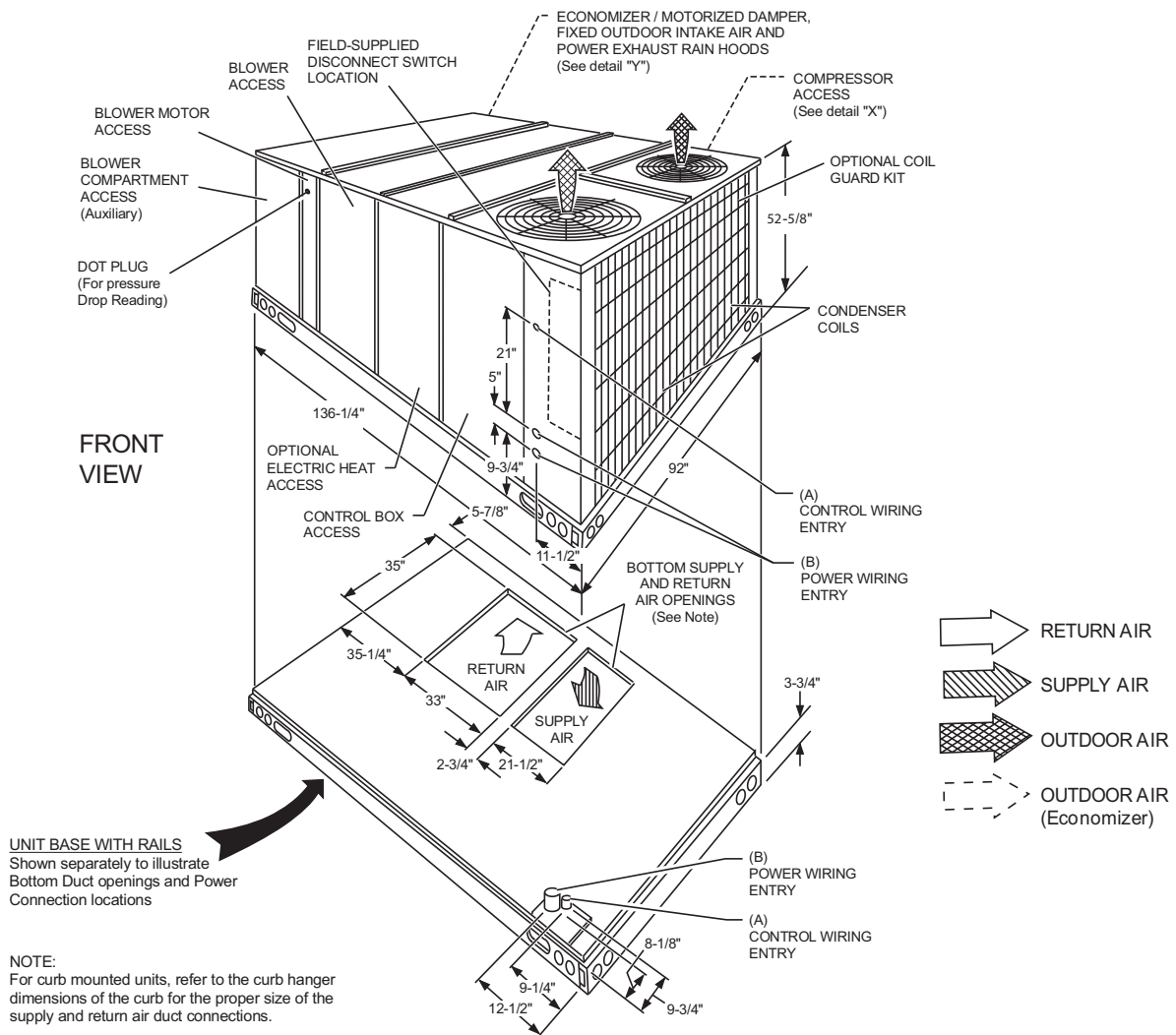

Utilities Entry

NOTE: All entry holes should be field sealed to prevent rain water entry into the building.

Hole	Opening Size Diameter	Used For	
A	1-1/8" KO	Control Wiring	Front
	3/4" NPS (Fem.)		Bottom
B	3-5/8" KO	Power Wiring	Front
	3" NPS (Fem.)		Bottom

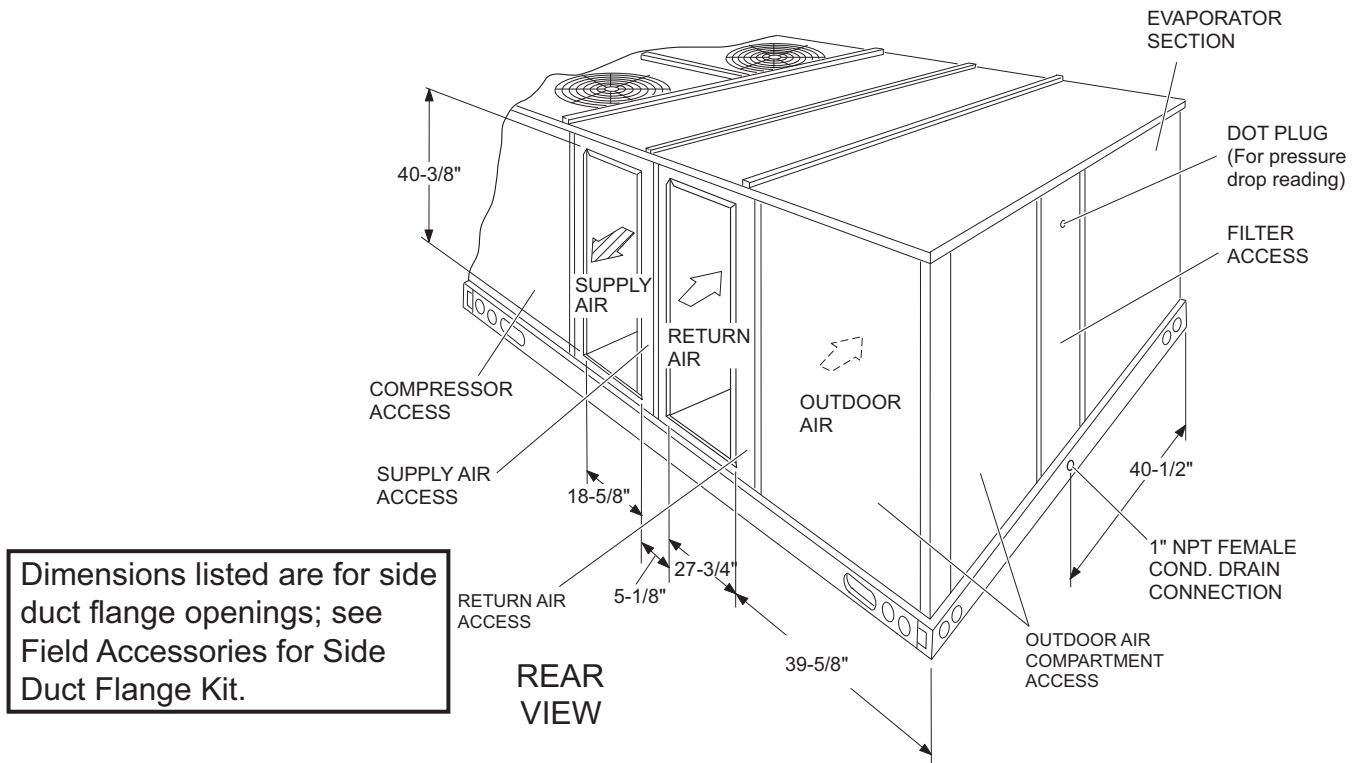
XP180/240 Unit Dimensions Rear View

NOTE: Units are shipped with the bottom duct openings covered. An accessory flange kit is available for connecting side ducts.

For bottom duct applications:

1. Remove the side panels from the supply and return air compartments to gain access to the bottom supply and return air duct covers.
2. Remove and discard the bottom duct covers. Duct openings are closed with sheet metal covers except when the unit includes a power exhaust option. The covering consists of a heavy black paper composition.
3. Replace the side supply and return air compartment panels.

For side duct applications:

1. Replace the side panels on the supply and return air compartments with the accessory flange kit panels.
2. Connect ductwork to the flanges on those panels.

XP Unit Dimensions Rain Hood

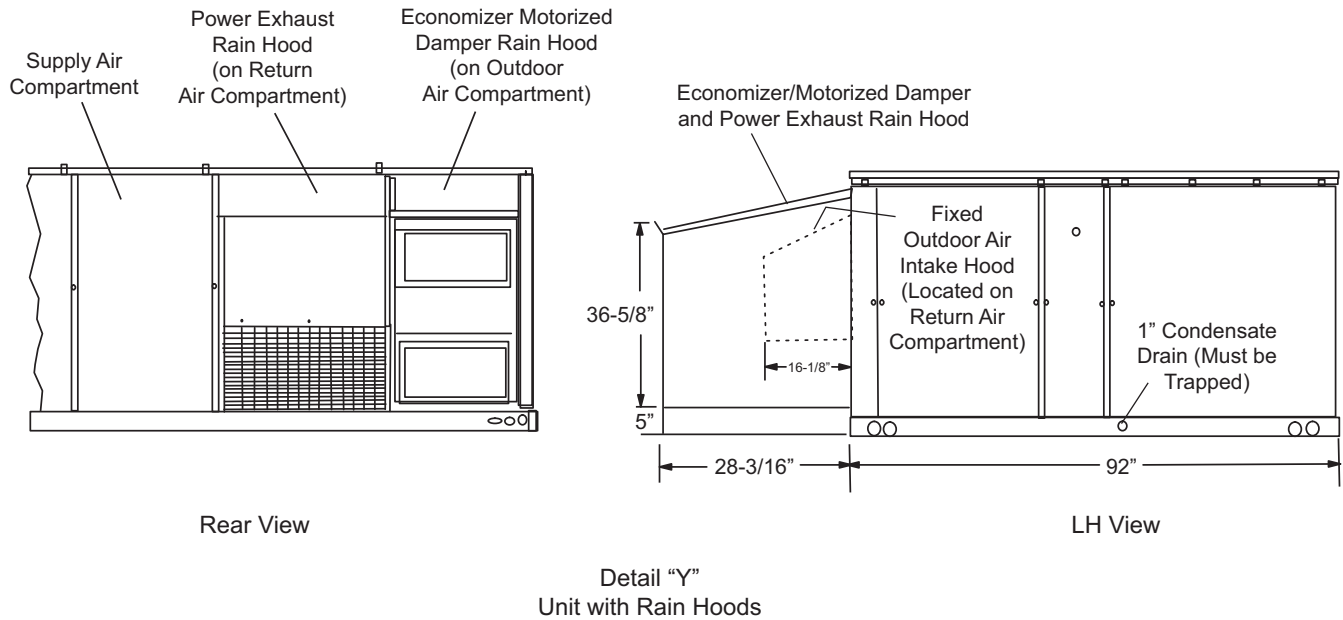

XP180/240 Unit Clearances

Direction	Distance (in.)	Direction	Distance (in.)
Top ¹	72 With 36 Maximum Horizontal Overhang (For Condenser Air Discharge)	Right	36
Front	36	Bottom ²	0
Rear	24 (W/O Economizer)	Left	24 (W/O Economizer)
	49 (W/Economizer)		36 (W/Economizer) ³

- Units must be installed outdoors. Over hanging structure or shrubs should not obscure condenser air discharge outlet.
- Units may be installed on combustible floors made from wood or class A, B or C roof covering materials.
- If economizer is factory installed, the unassembled rain hood must be removed from its side along position in front of the evaporator coil, or in the outdoor air compartment, prior to final installation.

Note: ALL Models: Units and ductwork are approved for zero clearance to combustible material when equipped with electric heaters.

Unit Accessory Dimensions

XP180/240 Roof Curb

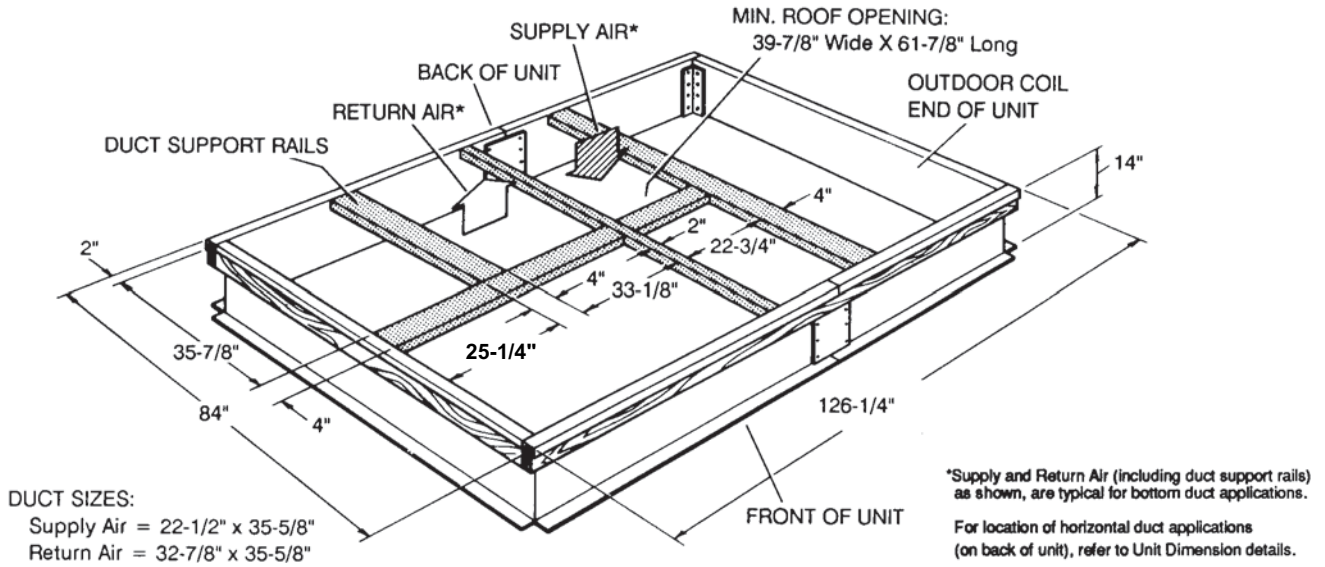

XP180/240 Roof Curb Duct Openings

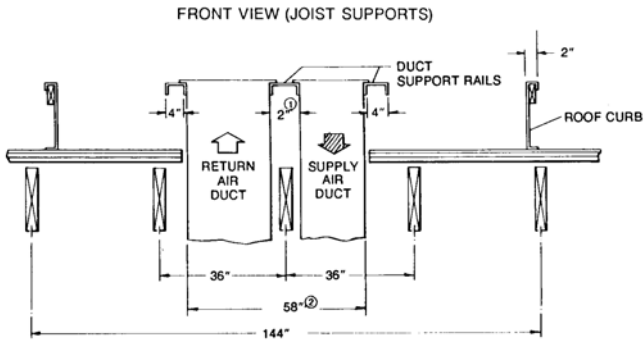

XP180/240 Cut Away of Roof Curb

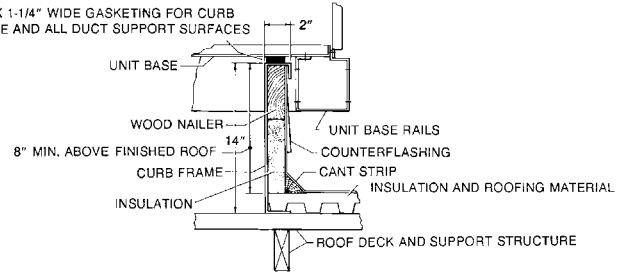

1. The 2" space between the ducts allows for "jumping" an existing roof joist.
2. The 58-1/2" overall dimension of the ducts allows ductwork penetration between roof joists that are spaced on 72" centers.

NOTE: Ducts can be installed into the curb from the roof. All electrical and gas line connections can be made inside the curb.

XP240 Typical Installation

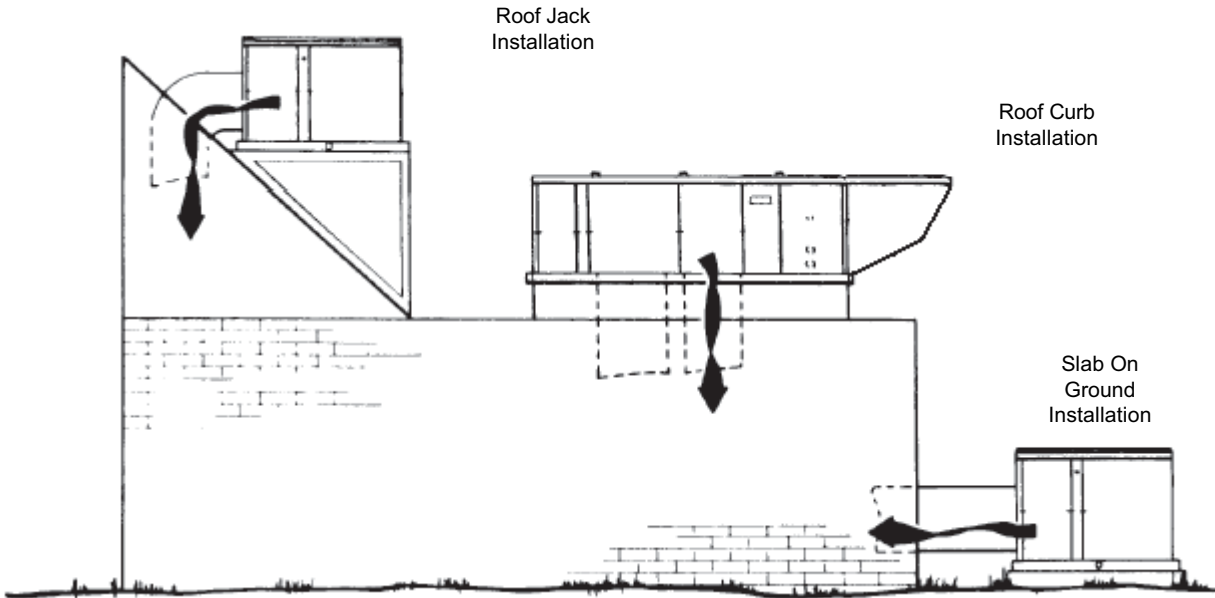

Subject to change without notice. Printed in U.S.A.
 Copyright © 2016 by Johnson Controls, Inc. All rights reserved.

5168280-YTG-B-0216
 Supersedes: 5168280-YTG-A-1115